

# screen technics catalogue

[www.screentechnics.com.au](http://www.screentechnics.com.au) | screen technics catalogue



ST  
**PROJECTION**  
SCREENS

ST  
**INTERFIT**  
LIFTERS

ST  
**CONNECT**  
CONTROL

ST  
**PEERLESS**  
MOUNTS

ST  
**PRO-BLIND**  
SYSTEMS

V 3.1

[www.screentechnics.com.au](http://www.screentechnics.com.au)



# contents

Product Type	Model Range	Page No.
About Screen Technics		1-8
Portable Screens	Vertical Up	12
	Tripod Screen	13
Manual Screens	Presenter	14
	CinemaPro Hi Contrast Grey	15
	CinemaPro	16
	CinemaTech Hi Contrast Grey	17
	CinemaTech	18
Fixed Screens	CinemaSnap Matt White	19-20
	CinemaSnap Matrix White	21
	CinemaSnap 235	22
	CinemaSnap Rear Projection	23
	CinemaSnap Micro Perforated	24
	CinemaSnap Accessories	25
Motorised	ViewMaster Pro	26
	ViewMaster Pro Screen Box	27
	Motorised Lecturer	28
	ElectriCinema Hi Contrast Grey	29
	ElectriCinema	30
	ElectriCinema XL	31
	Admiral	32
	ElectriCinema Screen Box	33
	ElectriCinema Side Tension	34
	ElectriCinema 235	35
	Trapdoor	36
	Trapdoor with Side Tension	37
	Screen Lowering Device	38
	Screen Lowering Device with Trapdoor	39
	Manual Swing Arm	40
	Motorised Swing Arm	41

# contents

Product Type	Model Range	Page No.
Commerical / Staging	Laceout	42
	Techfold Single Frame	43
	Replacement Surfaces	44
	Techfold Truss Frame	45
	Replacement Surface	46
	Drape Kits	47
Accessories	Connect Accessories	48
	Control Accessories	49
DNP	Supernova One	50
	Supernova Core	51
	Supernova Blade	52
	Supernova Epic	53
	Supernova Epic CS	54
	Supernova Infinity	55
	Rear Projection	56
	ST Mirror Bounce Modules	57
Motorised Projector Lifters	Projector Lifts	60-61
Motorised Flat Panel Lifters	Vertical Up	62 - 63
	Vertical Down	64 - 65
	Swing Down - Coming Soon	66
General Lifting Devices	Video Conference Camera Lift	67
AV Bracketing Systems	Projector Bracket	68
	Accessories	69 - 70
	Short Throw Bracket	71
	Security Cage	72
	Flat Panel Ceiling Bracket	73

# contents

Product Type	Model Range	Page No.
iConnect Motor Controller	240v Motor Controller	76 - 77
	24v Motor Controller	76 - 77
iReply	IP2	78 - 79
	IP4	78 - 79
	IP8	78 - 79
iSense Trigger Device	Current Sensing Trigger	80
	12V Trigger Device	80
Accessories	Connect	81
Flat Panel Floor Stands & Carts	Universal Stands & Carts	84 - 89
Projector Brackets	PRG-UNV	90
	PSM-UNV	91
Flat Panel Wall Mount	Univeral Ultra SlimLine	92-94
	SmartMount	95-100
Video Wall Mount	Full Service Video Wall Mount	101
Tilt Wall Mount	Universal tilt Wall Mount	102 - 107
Corner Mount	Universal Corner Mount	108 - 110
Articulating Wall Mount	Universal Ultra SlimLine	111 -112
	SmartMount	113 - 116
Blind Systems	How To Measure	119
	Mounting Options	120
	ST Chain Drive	121
	ST Motorised Roller Blinds	122
	Measure & Style Sheet	123
Terms & Conditions		124 - 126





# About Screen Technics

Starting in 1990 and continuing under the same leadership for over 23 years, Screen Technics is still the number one supplier of Projection Screens and AV Lifting devices in the Australian AV market. With an unparalleled reputation for high customer service, technical depth and custom engineered solutions, Screen Technics has long been the supplier of choice for the professional audio visual community.

Operating from its extensive manufacturing facilities, of over 10,000 square metres of capacity, in the beautiful Southern Highlands of NSW. With facilities including CNC Mills, CNC Lathes, CNC Punch Press, CNC Brake Press. Auto Desk Inventor 3D drawing package, Wet Spray Booths and Ultrasonic PVC welders, plus our own in-house powder coating facility. All staffed by local production and sales staff who understand all aspects of their product range...Screen Technics has the industrial muscle to be the best in category as a supplier.

Along with our industry leading range of Projection Screens and AV Lifting Devices, we also distribute a range of high end international AV brands, such as DNP and Peerless Mounts.

Screen Technics also manufactures other products within its extensive facility including AV Mounts, Connect Motor Control Solutions and Commercial / Domestic Blind Systems.

## What's New

- Green Guard Certification for many Fibre Glass Screen Materials, promoting healthy indoor air quality.
- Water based Black Boarder Paint System, removing harmful solvent based VOC's from the indoor environment.
- Mark 2 Electricinema released with IP Control integrated within the base screen canister. Plug in a Blue Cable and you're in command.
- Release of the Viewmaster Pro Series of Projection Screens with many of the features found in premium screens without the premium price.
- Release of High Contrast Grey Screen Material for Roller Screens, enhancing blacks and overall colour saturation
- Peerless range of Flat Panel Trolleys and Stands, perfect for the domestic or commercial environment.

We trust that our expanded product offering, in conjunction with our industry recognised "can do" culture, will ensure that when you purchase a Screen Technics product that no stone has been left unturned in the pursuit of excellence.

Greg Donovan  
Managing Director and Company Founder





## GENERAL INFORMATION

What size screen do I need?

The following diagrams explain the industry standard method for calculating the desired projection screen size, based on sitting position and average chair height, expecting a home theatre viewer to be seated in a lounge chair and a corporate viewer to be seated in an office or boardroom chair, which is traditionally higher in the seat.

This diagram is to be used as a guide only as many personal factors of preference will come into play when deciding this issue, but this is a good guide to start working from as a base - don't forget that the image throw characteristics of your projector will also be an important factor in screen size determination. Make sure that after you have decided on a screen size and a projector location that no physical obstacles will prevent your projector placement, thus requiring a re-size of the screen.

### Home Theatre Single • Seat Position

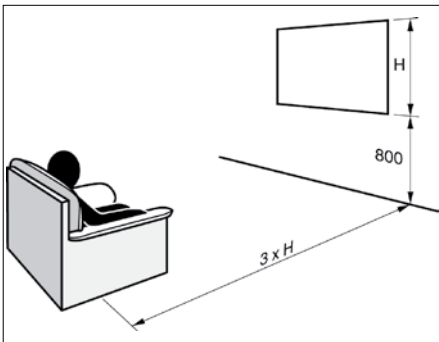

These standards apply to most formats.

The bottom measurement on diagram indicates the ideal floor to bottom of screen height, again as a guide only.

Example:

Viewer wishes to sit 4m from the screen.

$4\text{m}/3 = 1.3\text{m}$ , Screen Height = 1.3m

Then consider the following:

Available sizes, Site conditions, Customer requirements, Projector characteristics.

NB: Please consider 4 x height formula for 2.35:1 Cinemascope

### Corporate AV • Multi-position seating

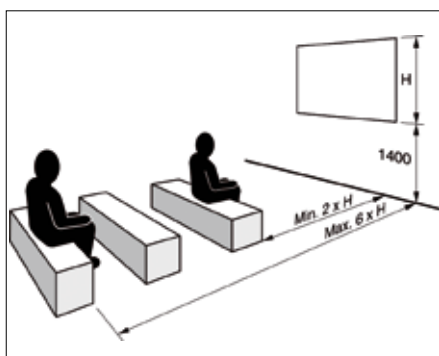

These standards apply to most formats.

The bottom measurement on diagram indicates the ideal floor to bottom of screen height, again as a guide only.

Example:

Closest viewer is 3m from screen furthest viewer is 8m away.

$3\text{m}/2 = 1.5\text{m}$  Max Height

$8\text{m}/6 = 1.3\text{m}$  Min Height

Then consider the following:

Available sizes, Site conditions, Customer requirements, Projector characteristics.

### Screen Borders and Leader Drop

Black masking borders are standard on all Screen Technics Front Projection Screens at no additional cost to user. Borders enhance the perceived brightness and contrast levels for the image on the screen and are therefore an absolute necessity for obtaining the best results from your projector.

Borders also allow the projected image to "bleed off" the screen and present a sharp edge to the viewer.

Standard borders on all roll down style screens (except the Admiral and Chancellor) are 50mm on each side (40mm sides and no top or bottom leader on AV square format) and 65mm to the bottom including slat rod and 50mm set at the top, with further adjustable leader capacity within the head box canister, which varies from product to product, so please contact the sales department for details.



## ASPECT RATIO / FORMATS

Aspect ratios describe the shape of the screen in regards to the width by the height, and choosing which format best suits the end user is a crucial decision.

In Australia / New Zealand the commonly used ratio formats are AV Square, Video 4:3, HDTV 16:9, with Cinemascope 2.35:1 and 16:10 formats becoming evermore popular.

Being a manufacturer, Screen Technics can make any screen format required.

### AV Square

Format is the width by drop being the same measurement, and is primarily used by educational facilities who use a combination of AV tools such as overhead projectors or computer generated projected images.

1 Unit W x 1 Unit H

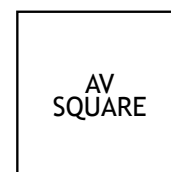

### Video 4:3

Format is the standard shape in most commercial environments where the projection of data is the primary aim. Most computer monitors are in Video 4:3 format.

4 Units W x 3 Units H



### HDTV 16:9

This format is the standard shape for all widescreen TVs and commonly used by DVD movie discs for widescreen displays, so this format is most suitable for DVD movie watchers.

16 Units W x 9 Units H



### 16:10

A newly created format that has become popular with laptop manufacturers for their LCD screens, and due to the change in their graphic output, projector manufacturers are releasing 16:10 chipped projectors for commercial environments.

16 Units W x 10 Units H

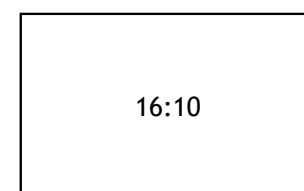

### Cinemascope 2.35:1

A long standing commercial theatre format, with the release of anamorphic lens technology allowing standard projectors to display a Cinemascope image, this dedicated movie format has recently entered the mainstream home theatre scene.

2.35 Units W x 1 Units H



### Screen Size Ordering & Custom Sizes

All sizes stated are net picture area, being the white viewing area and does not include any black border or leader dimensions.

It is common to refer to screen in inches and this is always the diagonal measurement, when talking metric it is the width by the drop or height that is generally being discussed.

Screen Technics is an Australian manufacturer and can therefore make up custom sizes to suit individual projects. Please ring the sales department to seek advice.

## SCREEN MATERIAL OPTIONS

### Unity White FG

- Standard on all manual roller screens (Max NPA 2340mm Wide)
- Standard on all manual chain drive screens (Max NPA 3050mm Wide)
- Standard on all motorised screens up to and including NPA 3320mm width and standard leader
- Stiff backing improves 'Layflat' qualities
- Unity Gain of **1.1**
- Industry Standard Material Worldwide

### Hi Contrast Grey

- Optional on select manual roller screens (Max NPA 2340mm Wide)
- Optional on manual chain drive screens (Max NPA 3050mm Wide)
- Optional on select motorised screens up to and including NPA 3320mm width
- Stiff backing improves 'Layflat' qualities
- Gain of **0.8**
- Lambertian standard viewing cone of 180 degrees
- Improves black levels and colour saturation

### Unity White PVC

- Standard welded surface for all roller screens over NPA of 3320mm width
- Standard on all Fixed Frame CinemaSnap screens
- Standard on all Side Tensioned screens due to stretching qualities
- Standard front projection Lace Out screens
- Unity Gain of **1.0**

### Hi Res Matrix White

- Superior Optical Structure for Sharper Resolution
- Improves colour saturation & anti hot spot
- Fabric Width 2000mm
- Used in Fixed Frame CinemaSnap screens only
- Grey backed & light tight for improved reflection levels
- Gain of **1.1**

### MicroPerf White

- This is not a woven fabric, but an authentic micro perforated material
- To be used for Centre Speaker placement behind screen
- Acoustically transparent
- Used in Fixed Frame CinemaSnap screens only
- Gain of **0.95**
- Fabric Width 2350mm
- Effects some high end sound frequencies

### RearFlex Grey

- Allows projection to be directed from the rear of the screen
- Welded surfaces over 2400mm width
- Suitable for all roller and fixed frame screens
- Suitable for Lace Out screens that don't require folding
- Solid Acrylic Screens from DNP will achieve a superior result

### RearFold Grey

- Allows projection to be directed from the rear of the screen
- Welded surfaces over 2400mm width
- Can be folded without damage
- Suitable for Lace Out & TechFold screens
- Not suitable for roller screens

### TwinFlex White

- Allows projection to be directed from the rear & front of the screen
- Image is viewable on both sides of screen
- Suitable for all roller & fixed frame screens and laceout
- Material width 2400mm



## SCREEN MATERIAL OPTIONS MATRIX

Screen Products	Unity White FG	Hi Contrast Grey	Unity White PVC	Hi Res Matrix White	MicroPerf White	CinemaPerf White	RearFlex Grey	RearFold Grey	TwinFlex White	ChromaKey Green
Vertical Up	S									
Tripod	S									
Presenter HT	S						O		O	
CinemaPro	S	O					O		O	O
CinemaTech	S	O					O		O	O
CinemaSnap			S	O	O	O	O		O	
CinemaSnap 235				S	S					
ViewMaster Pro	S									
Lecturer	150" & Under		Over 150"				O		O	O
ElectriCinema	150" & Under	O	Over 150"				O		O	O
ElectriCinema XL			S			O	O		O	
Admiral			S			O	O		O	
ElectriCinema Side Tension			S				O		O	
ElectriCinema 235			S							
Trapdoor Screen	150" & Under		Over 150"				O		O	O
Trapdoor Side Tension			S				O		O	
Screen Lowering Device	150" & Under		Over 150"				O		O	
Lace Out Projection			O		O	O	O		O	
TechFold			S			O		S	O	

S= Standard, O= Optional



## GREENGUARD

UL Environment's GREENGUARD Certification program helps manufacturers create, and buyers identify and trust, interior products and materials that have low chemical emissions, improving the quality of the air in which the products are used. All certified products must meet stringent emissions standards based on established chemical exposure criteria.

### GREENGUARD Gold Certification

GREENGUARD Gold Certification (formerly known as GREENGUARD Children & Schools Certification) offers stricter certification criteria, considers safety factors to account for sensitive individuals (such as children and the elderly), and ensures that a product is acceptable for use in environments such as schools and healthcare facilities. It is referenced by both The Collaborative for High Performance Schools (CHPS) and the Leadership in Energy and Environmental Design (LEED) Building Rating System.

### Emission Controls for Educational and Healthcare Environments

This standard is designed to define low-emitting materials suitable for environments where people, particularly children and sensitive adults, spend extended periods of time, in particular schools and healthcare facilities.

### SCREEN TECHNICS and GREENGUARD Gold Certification

A wide range of Screen Technics Projection Screen Systems now come with screen fabrics that have been GREENGUARD Gold Certified. Please see reference of which products are suitable via our website [www.screentechnics.com.au](http://www.screentechnics.com.au)

### Water Based Black Borders

But the screen fabric is not the end of the story. Screen Technics has removed all solvents from our black border painting system, removing all VOC content from our manufacturing process. No more will you enjoy the pungent smell of a new projection screen rolling down. That smell by the way, is not good for you...and with powder coated screen canisters instead of wet spay techniques, Screen Technics Projection Screens now offer a total system for a low VOC solution for indoor environments.

### What about Screen Boxes...are they Green?

You bet...all Screen Technics Screen Boxes are made with environmentally friendly E0 MDF that features a low formaldehyde formular to improve air quality outcomes. Again continuing Screen Technics efforts in supplying not only the best screen products, but the safest in category.

### GREENGUARD Technical - VOC & Chronic Reference Exposure Levels (CRELs)

The exposure to individual volatile organic compounds (VOCs), as detected in the C6 - C16 mass spectrometric analysis screen, has been adjusted to allow no greater than 1/100 of the currently published ACGIH® Threshold Limit Values (TLVs) and no greater than one-half of the California's Chronic Reference Exposure Levels (CRELs). In many cases, the 1/100 safety factor reduction of TLVs results in the most stringent requirements for an extensive range of VOCs. A total VOC or TVOC maximum allowable limit takes into account the complex mixture of all VOCs found to be emitting from a product, including those with and without TLVs or CRELs.



## Hi Contrast Grey

### Lambertian Screen Fabric

A self-supporting screen fabric that does not require side tensioning to achieve desired lay-flat qualities. Designed for straight cut roller screens. The grey surface offers excellent resolution characteristics and with a peak gain of 0.8 creates an ultra-wide viewing cone. It is available in a wide range of Screen Technics Roller Screen systems.

### Why a Grey Surface..?

When you don't have full control of ambient light conditions, the colour grey assists the projector in improving black levels in the colour spectrum, by shifting the contrast band towards the darker scale. This improves overall colour saturation, however with some loss of brightness. This is best offset by using high output projectors of 1500 ANSI Lumens or more.

## Contrast Shift by using Grey Coloured Surfaces

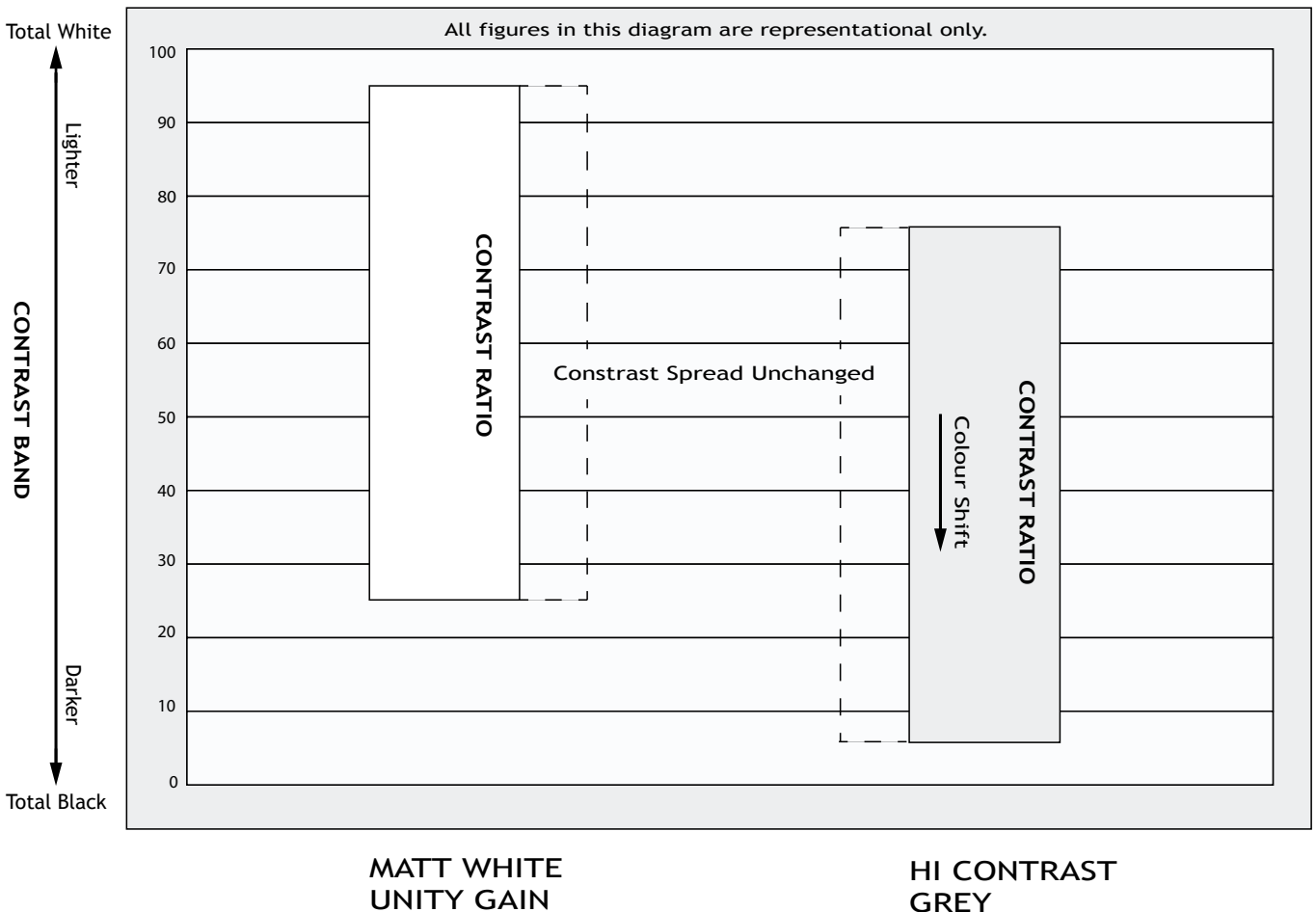

So you gain in black levels and lose in the white levels. How can this be a good thing? The reality is modern projectors don't struggle for brightness (white levels), but they constantly struggle for blacks (black levels). It is the black levels that control the perceived contrast on the screen, and contrast is the single biggest objective in projection, not brightness.

Can you use the Hi Contrast Grey screen in high light environments and achieve a good result...no, not really...it is not a cure for that issue, but is designed to assist in environments where some medium light leakage is inevitable. For example:

- Multipurpose rumpus / media rooms with white ceilings.
- Boardrooms without blackout blind systems.
- Function centres and Churches.

### Lambertian Screens

This term refers to a screen fabric having a full 180 degree viewing cone. Most high-gain screen fabrics reflect a bright viewing area to the centre of the viewing audience, which quickly dissipates the further off centre the viewer is watching from. At a certain point the viewer is receiving half the brightness of the central viewers, and this is considered the half-gain point of the screen fabric.

Lambertian screens have no half-gain position with a peak gain of 0.8, but actually disperse the brightness evenly and wide, so that the audience can be sitting way off centre and still receive optimal viewing conditions.

So if you have a wide viewing audience planned for your installation, consider the Lambertian aspects of the screen surface. The Hi Contrast Grey Surface is a GREENGUARD GOLD Certified product.

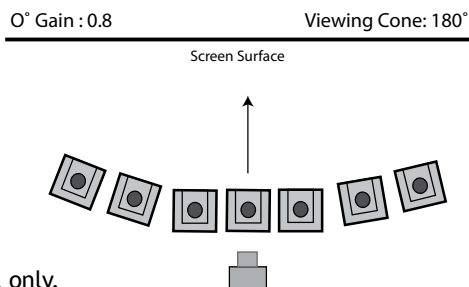

All figures in this diagram are representational only.

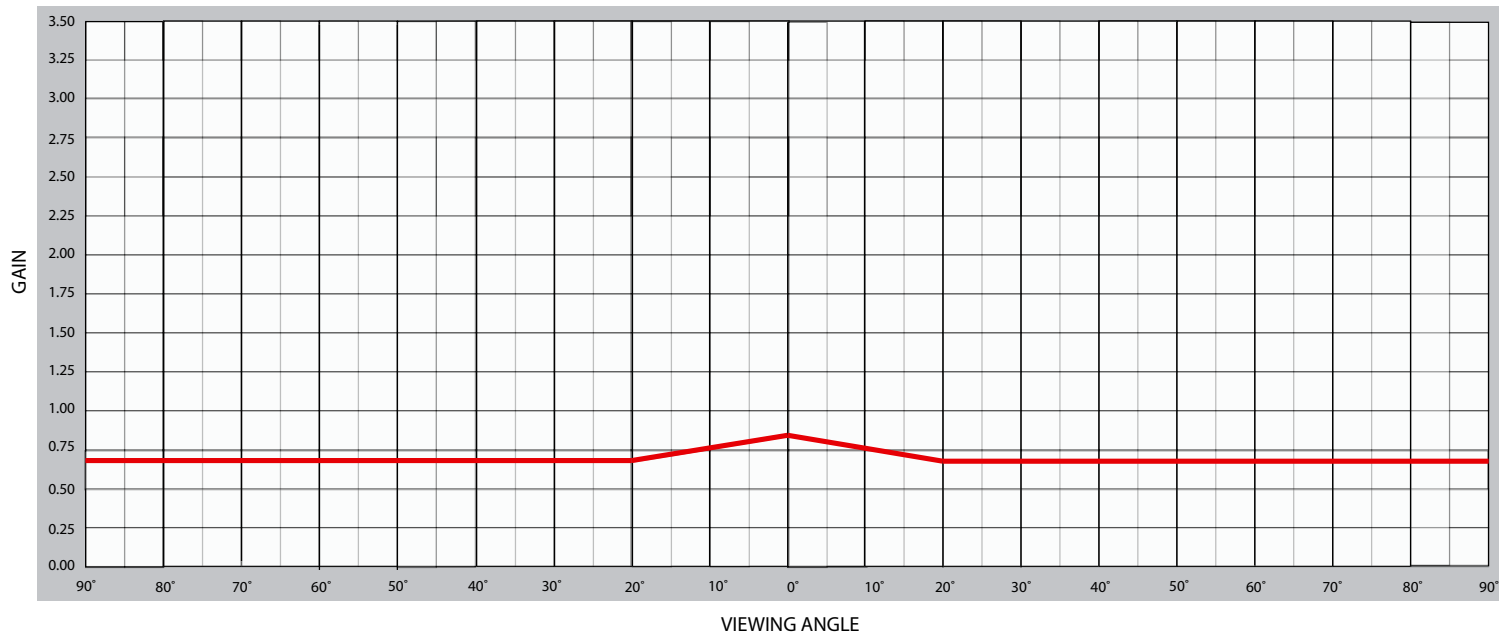



## Introduction



For over 23 years Screen Technics has been the projection screen standard by which the industry has measured itself in the Australian marketplace.

From small beginnings, we now are the largest manufacturer of projection screens in the country, bar none, and have a staff of over 50 people looking after the wants and needs of the Australian/New Zealand Audiovisual Industry, plus exporting to many countries around the world.

With a screen range of over 30 different models, available in over 500 distinct sizes ... plus the ability to manufacture custom solutions to suit ... why would you go anywhere else for a projection screen?

Our in-house sales team have extensive screen knowledge and highly regarded customer service levels, where they will endeavour to provide solutions for any AV environment you may encounter.

Over 95% of all Screen Technics products are manufactured right here in Australia, utilising precision CNC machinery and environmentally friendly processes. Not only do you get high quality hand built screens from people who have a vested interest in producing the very best, but we can continue to keep manufacturing alive in this country.

Thinking Screens ... Think Screen Technics.



Product Type	Model Range	Cat Page No
Portable Screens	Vertical Up	12
	Tripod Screen	13
Manual Screens	Presenter	14
	CinemaPro Hi Contrast Grey	15
	CinemaPro	16
	CinemaTech Hi Contrast Grey	17
	CinemaTech	18
Fixed Screens	CinemaSnap Matt White	19-20
	CinemaSnap Matrix White	21
	CinemaSnap 235	22
	CinemaSnap Rear Projection	23
	CinemaSnap Micro Perforated	24
	CinemaSnap Accessories	25
Motorised	ViewMaster Pro	26
	ViewMaster Pro Screen Box	27
	Motorised Lecturer	28
	ElectriCinema Hi Contrast Grey	29
	ElectriCinema	30
	ElectriCinema XL	31
	Admiral	32
	ElectriCinema Screen Box	33
	ElectriCinema Side Tension	34
	ElectriCinema 235	35

contents





contents

Product Type	Model Range	Cat Page No
Motorised Cont.d	Trapdoor	36
	Trapdoor with Side Tension	37
	Screen Lowering Device	38
	Screen Lowering Device with Trapdoor	39
	Manual Swing Arm	40
	Motorised Swing Arm	41
<b>Commercial / Staging</b>		
Commercial / Staging	Laceout	42
	Techfold Single Frame	43
	Replacement Surfaces	44
	Techfold Truss Frame	45
	Replacement Surface	46
	Drape Kits	47
<b>Accessories</b>		
Accessories	Connect Accessories	48
	Control Accessories	49
<b>DNP</b>		
DNP	Supernova One	50
	Supernova Core	51
	Supernova Blade	52
	Supernova Epic	53
	Supernova Epic CS	54
	Supernova Infinity	55
	Rear Projection	56
	ST Mirror Bounce Modules	57



## Portable Screens VERTICAL UP

Featuring an integrated aluminium carry case, a support frame operated by gas struts, this screen can be adjusted to any height as required. It is an easy to carry and store screen solution and should be your first selection for occasional home theatre or the presentation environment.



### BENEFITS

- Portable Projection Screen.
- Integrated Carry Handle.
- Height Adjustable.
- Black Headbox
- Gas Strut Mechanism



### APPLICATIONS

- Education & Training
- Government Projects
- Home Theatre

Item No	Nominal Inch Diagonal	Image Size mm	Format	Weight kg
RLVU06019B	60 Inch	915 x 1220	4:3	9.5
RLVU08019B	80 Inch	1215 x 1620	4:3	12.5
RLVU07569B	75 Inch	1012 x 1620	16:10	12.5

Please Note: This product is not suitable to be used in conjunction with a Short Throw Projector.

### PRODUCT FEATURES

- Description:** Premium vertical up screen with gas struts, perfect for the occasional home theatre or presentation
- Headbox:** Steel Head Box in Powder Coat Matt Black.
- Surface:** Matt White Fibreglass
- Size:** No wider than Net Picture Area 1620mm.

For more information on the Vertical Up please see our website or click here.





## Portable Screens

### TRIPOD SCREEN

This portable projection screen has a flexible operation and comes with integrated carry handle, so is perfect for those presentations on the go.



#### BENEFITS

- Portable Projection Screen.
- Integrated Carry Handle.
- Height Adjustable.
- Black Headbox



#### APPLICATIONS

- Education & Training
- Government Projects

#### PRODUCT FEATURES

- Description:** Tripod Screen is a basic entry level portable projection screen.
- Headbox:** Steel Head Box in Powder Coat Matt Black.
- Surface:** Matt White Fibreglass
- Size:** No wider than Net Picture Area 2360mm.

Item No	Nominal Inch Diagonal	Image Size mm	Format	Weight kg
RLTP12709B	n/a	1210 x 1210	Square	8
RLTP15309B	n/a	1470 x 1470	Square	11
RLTP18009B	n/a	1740 x 1740	Square	14
RLTP20309B	n/a	1950 x 1950	Square	15
RLTP24409B	n/a	2360 x 2360	Square	17
RLTP08419B	84 Inch	1237 x 1650	Video 4:3	11
RLTP10019B	100 Inch	1530 x 2030	Video 4:3	13
RLTP12019B	120 Inch	1770 x 2360	Video 4:3	16
RLTP06869B	68 Inch	920 x 1470	16:10	11

Please Note: This product is not suitable to be used in conjunction with a Short Throw Projector.

For more information on the Tripod please see our website or click here.



## Presenter

### COMMERCIAL HANGING TYPE

Value for money and simplicity of design makes these basic pull down screens ideal for educational and training facilities, with sturdy construction and incorporating a spring loaded return mechanism.

#### BENEFITS

- Value for money
- Simplicity of design
- Sure stop lock mechanism
- Rugged construction
- Surface Fire Rated

#### APPLICATIONS

- Education & Training
- Government Projects



#### PRODUCT FEATURES

- Description:** Presenter HT is a basic entry level manual spring operated screen.
- Head Box:** Steel Head Box in Powder Coat Matt Black - White optional, no charge.
- Surface:** Unity White FG Screen - Gain 1.1 Refer to page 5 for surface options
- Leaders:** Small Canister style is 50mm, Larger Canister Style is 200mm.
- Brackets:** Combo Bracket for Wall Fixing or Twin Hanging Points.
- Sizes:** No wider than Net Picture Area 2340mm.
- Roller Diameter:** Small Canister - 37mm Heavy Duty  
Large Canister - 50mm Heavy Duty
- Options:** Flat Ceiling Brackets - Pull Down Rod  
Rear Pro Surface available.

Tech Drawing  
Hyperlink :

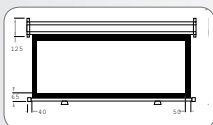

Item No.	Inch Diagonal	Image Size mm	Format	Weight kg
0211909-S	n/a	1190 x 1190	Square	9
0214409-S	n/a	1440 x 1440	Square	11
0217509-S	n/a	1750 x 1750	Square	15
0220509-L	n/a	2055 x 2055	Square	17
0223609-L	n/a	2360 x 2360	Square	19
0207219-S	72	1100 x 1465	Video 4:3	10
0208419-S	84	1280 x 1705	Video 4:3	12
0210019-L	100	1525 x 2035	Video 4:3	16
0211519-L	115	1755 x 2340	Video 4:3	18
0207229-S	72	895 x 1595	HDTV 16:9	12
0207829-S	78	973 x 1730	HDTV 16:9	14
0208429-L	84	1045 x 1860	HDTV 16:9	15
0209229-L	92	1145 x 2035	HDTV 16:9	16
0210029-L	100	1245 x 2215	HDTV 16:9	17
0210629-L	106	1316 x 2340	HDTV 16:9	18
0207269-S	72	970 x 1550	16:10	12
0208469-L	84	1130 x 1810	16:10	14
0209269-L	92	1240 x 1980	16:10	15
0209669-L	96	1295 x 2070	16:10	16
0210069-L	100	1345 x 2155	16:10	17
0210869-L	108	1460 x 2340	16:10	18

**Please Note:** This product is not suitable to be used in conjunction with a Short Throw Projector.

For more information on the Presenter please see our website or click here.





## CinemaPro HI CONTRAST GREY



### Why choose a Grey Screen ?

When you don't have full control of ambient light conditions the colour grey assists the projector in improving black levels in the colour spectrum by shifting the contrast band towards the darker scale. This improves overall colour saturation but with the loss of some brightness normally well compensated for by today's modern projectors.

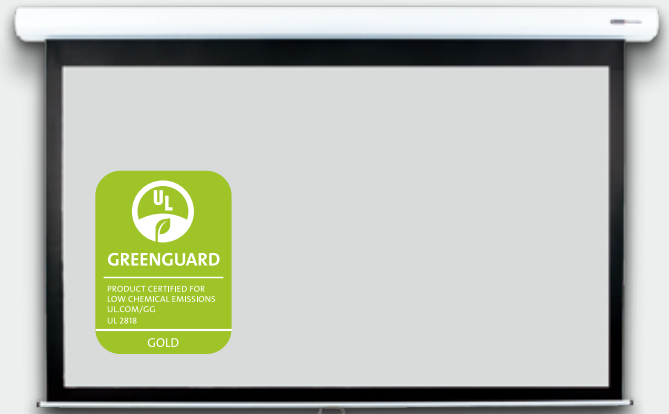

### What is a Lambertian Screen ?

The Hi Contrast Grey has a maximum gain of 0.8 which by definition creates the Lambertian effect of a 180 degrees wide viewing cone, with little brightness drop off when viewed from an extreme angle. Perfectly suitable for public space installations with a wide audience.



#### PRODUCT FEATURES

- Description:** Quality Home Theatre Manual Spring Operated Screen.
- Head Box:** Powder Coat White as standard with Silver or Black available.
- Surface:** Hi Contrast Grey - Gain 0.8
- Borders:** 50mm Sides & Bottom with 350mm Top Black Leader.
- Brackets:** One piece clip-on L bracket suitable for wall or ceiling installation.
- Sizes:** 72" Diagonal to 115" Diagonal - Custom Sizes & Formats available upon request.
- Roller Diameter:** 50mm Heavy Duty
- Options:** Custom Colours - Extra Top Masking
- Top Leader:** For sizes 100" and under the maximum total top black leader available is 500mm, for screen sizes over 100" the maximum top black leader available is 600mm.

Tech Drawing  
Hyperlink :

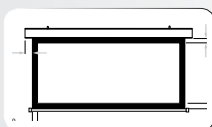

Item No.	Inch Diagonal	Image Size mm	Format	Weight kg
4407218	72"	1100 x 1465	Video 4:3	12
4408418	84"	1280 x 1705	Video 4:3	14
4410018	100"	1525 x 2035	Video 4:3	16
4411518	115"	1755 x 2340	Video 4:3	17
4407228	72"	895 x 1595	HDTV 16:9	12
4408428	84"	1045 x 1860	HDTV 16:9	14
4409228	92"	1145 x 2035	HDTV 16:9	15
4409628	96"	1195 x 2125	HDTV 16:9	15.5
4410028	100"	1245 x 2215	HDTV 16:9	16
4410628	106"	1316 x 2340	HDTV 16:9	17
4407268	72"	970 x 1550	16:10	12
4408468	84"	1130 x 1810	16:10	14
4409268	92"	1240 x 1980	16:10	15
4409668	96"	1295 x 2070	16:10	15.5
4410068	100"	1345 x 2155	16:10	16
4410868	108"	1460 x 2340	16:10	17

Custom sizes & Formats available upon request.

**Please Note: This product is not suitable to be used in conjunction with a Short Throw Projector.**

Surface Fire Rated

For more information on the CinemaPro please see our website or click here.





## CinemaPro PREMIUM PULL DOWN SCREEN

A stylish Home Theatre solution for when a manual spring operated screen is preferred, the CinemaPro features a designer canister to suit modern home decor requirements and utilises a hidden universal bracket system. Perfect for the multi-purpose living room / home theatre.

### BENEFITS

- Value for money
- Designer good looks
- Hidden Brackets
- Fully Retractable Surface

### APPLICATIONS

- Home Theatre
- Boardroom Presentations
- Educational & Training Facilities



### PRODUCT FEATURES

- Description:** Quality Home Theatre Manual Spring Operated Screen.
- Head Box:** Powder Coat White as standard with Silver or Black available.
- Surface:** Unity White FG Screen-Gain 1.1 Refer to page 5 for surface options
- Borders:** 50mm Sides & Bottom with 350mm Top Black Leader.
- Brackets:** One piece clip-on L bracket suitable for wall or ceiling installation.
- Sizes:** 72" Diagonal to 115" Diagonal Custom Sizes & Formats available upon request.
- Roller Diameter:** 50mm Heavy Duty
- Options:** ChromaKey Surface, Custom Colours, Extra Top Masking
- Top Leader:** For sizes 100" and under the maximum total top black leader available is 500mm, for screen sizes over 100" the maximum top black leader available is 600mm.

Tech Drawing  
Hyperlink :

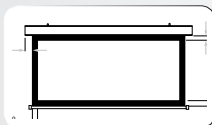

Item No.	Inch Diagonal	Image Size mm	Format	Weight kg
4407219	72"	1100 x 1465	Video 4:3	12
4408419	84"	1280 x 1705	Video 4:3	14
4410019	100"	1525 x 2035	Video 4:3	16
4411519	115"	1755 x 2340	Video 4:3	17
4407229	72"	895 x 1595	HDTV 16:9	12
4408429	84"	1045 x 1860	HDTV 16:9	14
4409229	92"	1145 x 2035	HDTV 16:9	15
4409629	96"	1195 x 2125	HDTV 16:9	15.5
4410029	100"	1245 x 2215	HDTV 16:9	16
4410629	106"	1316 x 2340	HDTV 16:9	17
4407269	72"	970 x 1550	16:10	12
4408469	84"	1130 x 1810	16:10	14
4409269	92"	1240 x 1980	16:10	15
4409669	96"	1295 x 2070	16:10	15.5
4410069	100"	1345 x 2155	16:10	16
4410869	108"	1460 x 2340	16:10	17

Custom sizes & Formats available upon request.

**Please Note:** This product is not suitable to be used in conjunction with a Short Throw Projector.

Surface Fire Rated

For more information on the CinemaTech please see our website or click here.



## CinemaTech HI CONTRAST GREY



### Why choose a Grey Screen ?

When you don't have full control of ambient light conditions the colour grey assists the projector in improving black levels in the colour spectrum by shifting the contrast band towards the darker scale. This improves overall colour saturation but with the loss of some brightness normally well compensated for by today's modern projectors.

### What is a Lambertian Screen ?

The Hi Contrast Grey has a maximum gain of 0.8 which by definition creates the Lambertian effect of a 180 degrees wide viewing cone, with little brightness drop off when viewed from an extreme angle. Perfectly suitable for public space installations with a wide audience.



#### PRODUCT FEATURES

- Description:** Quality Home Theatre Manual Chain Drive Screen System.
- Head Box:** Powder Coat White as standard with Silver or Black optional.
- Surface:** Hi Contrast Grey - Gain 0.8
- Borders:** 50mm Sides & Bottom with 300mm top black leader.
- Brackets:** One piece clip-on L bracket suitable for wall or ceiling installation.
- Sizes:** 72" Diagonal to 150" Diagonal. Custom Sizes & Formats available upon request.
- Roller Diameter:** Small Canister - 47mm Heavy Duty  
Large Canister - 80mm Heavy Duty
- Options:** Custom Colours - Extra Top Masking  
LHS Chain can be moved to RHS.
- Top Leader:** For sizes 100" and under the maximum total top black leader available is 500mm, for screen sizes over 100" the maximum top black leader available is 600mm.

Tech Drawing  
Hyperlink :

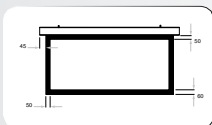

Please Note: 110" & over are supplied with a white nylon chain.

Surface Fire Rated

Item No	Inch Diagonal	Image Size mm	Format	Weight kg
4307218-S	72"	1100 x 1465	Video 4:3	11
4308418-S	84"	1280 x 1705	Video 4:3	13
4310018-S	100"	1525 x 2035	Video 4:3	15
4311018-S	110"	1676 x 2235	Video 4:3	28
4311518-L	115"	1755 x 2340	Video 4:3	29
4312018-L	120"	1830 x 2440	Video 4:3	30
4313018-L	130"	1980 x 2640	Video 4:3	33
4314018-L	140"	2135 x 2845	Video 4:3	36
4315018-L	150"	2285 x 3050	Video 4:3	39
4307228-S	72"	895 x 1595	HDTV 16:9	11
4308428-S	84"	1045 x 1860	HDTV 16:9	13
4309228-S	92"	1145 x 2035	HDTV 16:9	14
4309628-S	96"	1195 x 2125	HDTV 16:9	14.5
4310028-S	100"	1245 x 2215	HDTV 16:9	15
4311028-L	110"	1370 x 2435	HDTV 16:9	27
4312028-L	120"	1495 x 2655	HDTV 16:9	30
4313028-L	130"	1615 x 2880	HDTV 16:9	33
4313528-L	135"	1680 x 2990	HDTV 16:9	35
4307268-S	72"	970 x 1550	16:10	11
4308468-S	84"	1130 x 1810	16:10	13
4309268-S	92"	1240 x 1980	16:10	14
4309668-S	96"	1295 x 2070	16:10	14.5
4310068-S	100"	1345 x 2155	16:10	15
4311068-L	110"	1480 x 2370	16:10	26
4312068-L	120"	1615 x 2585	16:10	29
4313068-L	130"	1750 x 2800	16:10	32
4314068-L	140"	1884 x 3015	16:10	35

Custom sizes & Formats available upon request.

Please Note: This product is not suitable to be used in conjunction with a Short Throw Projector.

For more information on the CinemaTech please see our website or click here.



## CinemaTech

### PREMIUM CHAIN DRIVE ROLLER SCREEN

The Ultimate Manual Home Theatre Screen. Utilising a unique Chain Drive Lifting System, this Screen has no “pull down” stress placed upon it, so the Lay-Flat qualities last & last. With infinite adjustment for screen placement the screen is a dream to use and lock into position.

Chain drive offers longer life and improved lay-flat.

#### BENEFITS

- Value for money
- Simplicity of design
- Sure stop lock mechanism
- Rugged construction
- Surface Fire Rated

#### APPLICATIONS

- Education & Training
- Government Projects

#### PRODUCT FEATURES

**Description:** Quality Home Theatre Manual Chain Drive Screen System.

**Head Box:** Powder Coat White as standard with Silver or Black optional.

**Surface:** Unity White FG Screen Gain 1.1 Refer to page 5 for surface options

**Borders:** 50mm Sides & Bottom with 300mm top black leader.

**Brackets:** One piece clip-on L bracket suitable for wall or ceiling installation.

**Sizes:** 72” Diagonal to 150” Diagonal. Custom Sizes & Formats available upon request.

**Roller Diameter:** Small Canister - 47mm Heavy Duty  
Large Canister - 80mm Heavy Duty

**Options:** ChromaKey Surface, Custom Colours, Extra Top Masking, LHS Chain can be moved to RHS.

**Top Leader:** For sizes 100” and under the maximum total top black leader available is 500mm, for screen sizes over 100” the maximum top black leader available is 600mm.

Tech Drawing  
Hyperlink :

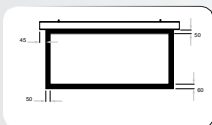

Please Note: 110” & over are supplied with a white nylon chain.

For more information on the CinemaTech please see our website or click here.



Item No	Inch Diagonal	Image Size mm	Format	Weight kg
4307219-S	72”	1100 x 1465	Video 4:3	11
4308419-S	84”	1280 x 1705	Video 4:3	13
4310019-S	100”	1525 x 2035	Video 4:3	15
4311019-S	110”	1676 x 2235	Video 4:3	28
4311519-L	115”	1755 x 2340	Video 4:3	29
4312019-L	120”	1830 x 2440	Video 4:3	30
4313019-L	130”	1980 x 2640	Video 4:3	33
4314019-L	140”	2135 x 2845	Video 4:3	36
4315019-L	150”	2285 x 3050	Video 4:3	39
4307229-S	72”	895 x 1595	HDTV 16:9	11
4308429-S	84”	1045 x 1860	HDTV 16:9	13
4309229-S	92”	1145 x 2035	HDTV 16:9	14
4309629-S	96”	1195 x 2125	HDTV 16:9	14.5
4310029-S	100”	1245 x 2215	HDTV 16:9	15
4311029-L	110”	1370 x 2435	HDTV 16:9	27
4312029-L	120”	1495 x 2655	HDTV 16:9	30
4313029-L	130”	1615 x 2880	HDTV 16:9	33
4313529-L	135”	1680 x 2990	HDTV 16:9	35
4307269-S	72”	970 x 1550	16:10	11
4308469-S	84”	1130 x 1810	16:10	13
4309269-S	92”	1240 x 1980	16:10	14
4309669-S	96”	1295 x 2070	16:10	14.5
4310069-S	100”	1345 x 2155	16:10	15
4311069-L	110”	1480 x 2370	16:10	26
4312069-L	120”	1615 x 2585	16:10	29
4313069-L	130”	1750 x 2800	16:10	32
4314069-L	140”	1884 x 3015	16:10	35

Custom sizes & Formats available upon request.

Please Note: This product is not suitable to be used in conjunction with a Short Throw Projector.



## CinemaSnap MATT WHITE FIXED FRAME

Setting the benchmark for perfect lay flat and ease of installation, this fixed screen system is designed to complement modern home theatre design, utilising a dedicated wall space.

Easy to install and never requires re-tensioning of the screen surface!

### BENEFITS

- Perfect lay flat
- Easy to install
- Contemporary design
- No moving parts
- Surface Fire Rated

### APPLICATIONS

- Home Theatre
- Data Projection
- Boardroom Presentations
- Government Projects



### PRODUCT FEATURES

- Description:** Fixed Frame Screen - ready to assemble - best possible lay-flat qualities
- Frame:** Black Powdercoat Finish for Increased Contrast and Overscan Protection.
- Surface:** Easy snap on screen surface - Unity White PVC - Gain 1.0  
Refer to page 5 for surface options
- Borders:** As per frame system - 80mm wide
- Brackets:** MultiTech Wall Brackets
- Sizes:** 72" Diagonal up to 425" Diagonal  
Custom Sizes & Formats available upon request.
- Options:** Matrix White - Rear Projection - Micro Perforated Surfaces - Flocke Frame Optional

Tech Drawing  
Hyperlink :

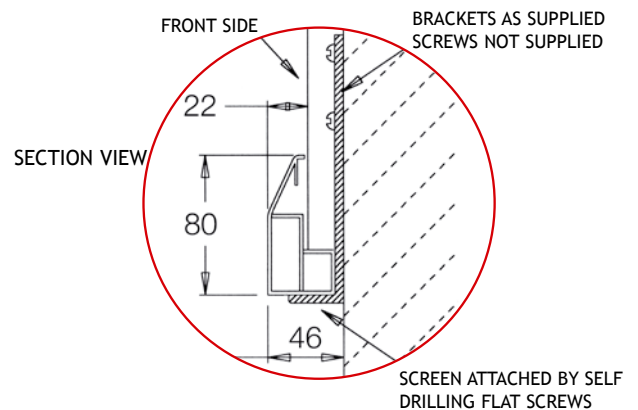
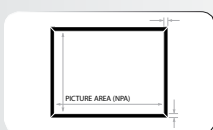

The CinemaSnap frame system utilises the structure of the wall to provide frame rigidity. If you intend to not use the wall but some other method of mounting please contact the sales office for advice on any engineering alterations that may be required.

Custom Sizes & Formats available upon request.

For more information on the CinemaSnap please see our website or click here.



## CinemaSnap MATT WHITE FIXED FRAME

Setting the benchmark for perfect lay flat and ease of installation, this fixed screen system is designed to complement modern home theatre design, utilising a dedicated wall space.

Easy to install and never requires re-tensioning of the screen surface!



Item No.	Inch Diagonal	Image Size (mm)	Format	Weight kg
1207219	72"	1100 x 1465	Video 4:3	16
1208419	84"	1280 x 1705	Video 4:3	17
1209619	96"	1460 x 1950	Video 4:3	18
1210019	100"	1525 x 2035	Video 4:3	19
1211019	110"	1676 x 2235	Video 4:3	21
1211519	115"	1755 x 2340	Video 4:3	22
1212019	120"	1830 x 2440	Video 4:3	23
1213019	130"	1980 x 2640	Video 4:3	26
1215019	150"	2285 x 3050	Video 4:3	30
1218019	180"	2745 x 3660	Video 4:3	35
1220019	200"	3050 x 4065	Video 4:3	29
1222519	225"	3430 x 4570	Video 4:3	44
1225019XL	250"	3810 x 5080	Video 4:3	90
1227519XL	275"	4190 x 5590	Video 4:3	95
1230019XL	300"	4570 X 6100	Video 4:3	100
1232519XL	325"	4950 X 6605	Video 4:3	105
1235019XL	350"	5330 X 7110	Video 4:3	110
1237519XL	375"	5715 x 7620	Video 4:3	115
1240019XL	400"	6100 X 8130	Video 4:3	120
1242519XL	425"	6475 x 8635	Video 4:3	125
1207229	72"	895 x 1595	HDTV 16:9	13
1208429	84"	1046 x 1860	HDTV 16:9	16
1209229	92"	1145 x 2035	HDTV 16:9	17
1209629	96"	1195 x 2125	HDTV 16:9	18
1210029	100"	1245 x 2215	HDTV 16:9	19
1211029	110"	1370 x 2435	HDTV 16:9	21
1211529	115"	1430 x 2545	HDTV 16:9	22
1212529	125"	1555 x 2770	HDTV 16:9	24
1213029	130"	1615 x 2880	HDTV 16:9	25

Item No.	Inch Diagonal	Image Size (mm)	Format	Weight kg
1213529	135"	1680 x 2990	HDTV 16:9	26
1214029	140"	1740 x 3100	HDTV 16:9	27
1215029	150"	1865 x 3320	HDTV 16:9	29
1218029	180"	2240 x 3985	HDTV 16:9	34
1220029	200"	2490 x 4425	HDTV 16:9	38
1222529	225"	2801 x 4980	HDTV 16:9	43
1225029XL	250"	3115 X 5535	HDTV 16:9	85
1227529XL	275"	3425 X 6085	HDTV 16:9	90
1230029XL	300"	3735 X 6640	HDTV 16:9	95
1232529XL	325"	4045 x 7195	HDTV 16:9	100
1235029XL	350"	4355 x 7745	HDTV 16:9	105
1237529XL	375"	4670 x 8300	HDTV 16:9	110
1240029XL	400"	4980 x 8855	HDTV 16:9	115
1207269	72"	970 x 1550	16:10	13
1208469	84"	1130 x 1810	16:10	16
1209269	92"	1240 x 1980	16:10	17
1209669	96"	1295 x 2070	16:10	18
1210069	100"	1345 x 2155	16:10	19
1211069	110"	1480 x 2370	16:10	21
1212069	120"	1615 x 2585	16:10	23
1213069	130"	1750 x 2800	16:10	24
1214069	140"	1884 x 3015	16:10	27
1215069	150"	2020 x 3230	16:10	29
1218069	180"	2425 x 3880	16:10	34
1220069	200"	2690 x 4310	16:10	38
1222569	225"	3030 x 4850	16:10	43
1225069XL	250"	3365 x 5385	16:10	85
1227569XL	275"	3705 x 5925	16:10	90
1230069XL	300"	4040 x 6465	16:10	95
1232569XL	325"	4375 x 7005	16:10	100
1235069XL	350"	4715 x 7540	16:10	105
1237569XL	375"	5050 x 8080	16:10	110
1240069XL	400"	5385 x 8620	16:10	115

Custom Sizes & Formats available upon request.

Surface Fire Rated



For more information on the CinemaSnap please see our website or click here.



## CinemaSnap

### HI RES MATRIX WHITE FIXED FRAME



High Colour Saturation

Low Colour Saturation



High Resolution

Low Resolution

A premium projection screen material that is specifically designed to enhance the home theatre experience.

Through improved resolution technology and utilising state of the art optical structures on the front of the surface and a light-tight grey backing, the new Matrix White surface in conjunction with the CinemaSnap fixed frame system is today's ultimate screen for LCD or DLP Projectors.



#### HI RES MATRIX WHITE IMPROVES

- Resolution
- Colour Saturation
- Anti-Hot Spotting
- Brightness Levels.
- Off Axis Viewing

Hi Res Matrix White has a unique micro-textured surface which displays a sharper resolution level and the grey backing allows no projected light to pass through the fabric, therefore increasing brightness levels over the standard matt white fabric, through improved reflection of the projected light.

#### PRODUCT FEATURES

- Hidden mounting system
- Powder coated aluminium frame
- Bevelled frame edges
- Unique SNAP surface fixing system
- Surface under constant tension for optimum lay flat
- Includes wall mounting brackets
- Custom Sizes and format ratios available
- Flocke frame optional

Tech Drawing  
Hyperlink :



Item No	Inch Diagonal	Image Size mm	Format	Weight kg
1207216	72"	1100 x 1465	Video 4:3	16
1208416	84"	1280 x 1705	Video 4:3	17
1209616	96"	1460 x 1950	Video 4:3	18
1210016	100"	1525 x 2035	Video 4:3	19
1211516	115"	1755 x 2340	Video 4:3	22
1212016	120"	1830 x 2440	Video 4:3	23
1213016	130"	1980 x 2640	Video 4:3	26
1207226	72"	895 x 1595	HDTV 16:9	13
1208426	84"	1046 x 1860	HDTV 16:9	16
1209226	92"	1145 x 2035	HDTV 16:9	17
1209626	96"	1195 x 2125	HDTV 16:9	18
1210026	100"	1245 x 2215	HDTV 16:9	19
1211026	110"	1370 x 2435	HDTV 16:9	21
1211526	115"	1430 x 2545	HDTV 16:9	22
1212526	125"	1555 x 2770	HDTV 16:9	24
1213026	130"	1615 x 2880	HDTV 16:9	25
1213526	135"	1680 x 2990	HDTV 16:9	26
1214026	140"	1740 x 3100	HDTV 16:9	27
1215026	150"	1865 x 3320	HDTV 16:9	29
1207246	72"	715 x 1685	Cinemascope 2.35:1	17
1208446	84"	835 x 1965	Cinemascope 2.35:1	18
1209246	92"	915 x 2155	Cinemascope 2.35:1	19
1209646	96"	955 x 2245	Cinemascope 2.35:1	20
1210046	100"	995 x 2340	Cinemascope 2.35:1	22
1211046	110"	1095 x 2575	Cinemascope 2.35:1	23
1212046	120"	1195 x 2810	Cinemascope 2.35:1	25
1213046	130"	1295 x 3054	Cinemascope 2.35:1	26
1214046	140"	1395 x 3280	Cinemascope 2.35:1	28
1215046	150"	1495 x 3515	Cinemascope 2.35:1	30

Custom Sizes & Formats available upon request.

For more information on the CinemaSnap please see our website or click here.



## CinemaSnap 235 WITH MOTORISED MASKING

2.35:1 CINEMASCOPE TO 16:9 HDTV AT THE PUSH OF A BUTTON.

Designed to work with projectors that utilise Anamorphic Lens technology.

The ultimate Home Theatre experience is Cinemascope, just as the movie studios intended it to be ... and with the new CinemaSnap 235 you can have the best of both worlds, 2.35:1 Cinemascope for the DVD movie and by utilising the motorised side masking system, reshape the screen to 16:9 HDTV for widescreen TV broadcasts.

For the dedicated Home Theatre there is nothing that compares with the perfect lay flat of a fixed frame screen and the Matrix White surface delivers the additional resolution and colour saturation that has become an industry hallmark for cinema perfection. Combined with 235 side masking, you have the very best Home Theatre solution available.

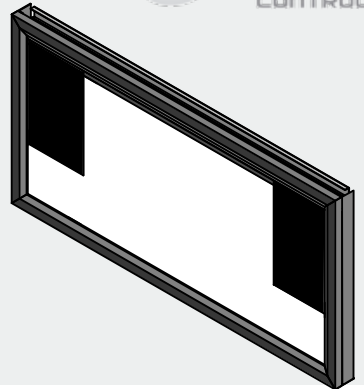

### BENEFITS

- Original Movie Aspect Ratio 2.35:1
- Integrated Side Masking for 16:9
- Perfect Lay Flat Qualities
- Flush Sitting Masking with no shadow-line



### APPLICATIONS

- Home Theatre

### PRODUCT FEATURES

**Description:** Wall mounted screen system with side masking for dual format Cinemascope to HDTV formats.

**Frame:** Aluminium constructions with Flocked frame for projector over-scan reduction.

**Surface:** Hi Res Matrix White or MicroPerf White. Refer to page 5 for surface options

**Sizes:** 84" Diagonal up to 150" Diagonal Custom Sizes & Formats available upon request.

Tech Drawing  
Hyperlink :

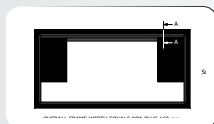

Also available in alternate CinemaScope format, e.g 2.40:1 / 2.37:1

Custom Sizes & Formats available upon request.

### CINEMASNAP 235 WITH HI RES MATRIX WHITE SURFACE

Item No	Inch Diagonal	Image Size 2.35:1	Image Size 16:9
5708446	84"	835 x 1965	835 x 1485
5709246	92"	915 x 2155	915 x 1625
5709646	96"	955 x 2245	955 x 1700
5710046	100"	995 x 2340	995 x 1770
5711046	110"	1095 x 2575	1095 x 1950
5712046	120"	1195 x 2810	1195 x 2125
5713046	130"	1295 x 3045	1295 x 2305
5714046	140"	1395 x 3280	1395 x 2480
5715046	150"	1495 x 3515	1495 x 2660

### CINEMASNAP 235 WITH MICROPERF WHITE SURFACE

Item No	Inch Diagonal	Image Size 2.35:1	Image Size 16:9
5708443	84"	835 x 1965	835 x 1485
5709243	92"	915 x 2155	915 x 1625
5709643	96"	955 x 2245	955 x 1700
5710043	100"	995 x 2340	995 x 1770
5711043	110"	1095 x 2575	1095 x 1950
5712043	120"	1195 x 2810	1195 x 2125
5713043	130"	1295 x 3045	1295 x 2305
5714043	140"	1395 x 3280	1395 x 2480
5715043	150"	1495 x 3515	1495 x 2660

For more information on the CinemaSnap 235 please see our website or click here.



## CinemaSnap REAR PROJECTION

The CinemaSnap fixed frame screen system can be utilised with rear projection material to allow for projector placement behind the screen, for use in a high light environment and where a trainer / presenter can move in front of the screen without blocking the light beam. It also removes the projector from the working area and provides a better contrast ratio.

It is our recommendation that a minimum lens throw ratio of 1.3:1 is used for this type of surface and it is definitely not suitable for short throw projectors. As a rule the higher the lens throw ratio & the longer the throw distance the better the resulting image.

### BENEFITS

- Perfect lay flat
- Easy to install
- Contemporary design
- No moving parts



### APPLICATIONS

- Home Theatre
- Data Projection
- Boardroom Presentations
- Government Projects

### PRODUCT FEATURES

- Description:** Fixed Frame Screen - ready to assemble - best possible lay-flat qualities
- Frame:** Black Powdercoat Finish for Increased Contrast and Overscan Protection.
- Surface:** Easy snap on screen surface  
RearFlex Grey  
Refer to page 5 for surface options
- Borders:** As per frame system - 80mm wide
- Brackets:** MultiTech Wall Brackets
- Sizes:** 72" Diagonal up to 425" Diagonal  
Custom Sizes & Formats available upon request.
- Options:** Flocke Frame Optional

Tech Drawing  
Hyperlink :

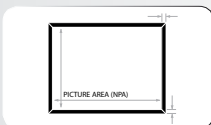

Custom Sizes & Formats available upon request.



Item No	Inch Diagonal	Image Size mm	Format	Weight kg
1207215	72"	1100 x 1465	Video 4:3	16
1208415	84"	1280 x 1705	Video 4:3	17
1209615	96"	1460 x 1950	Video 4:3	18
1210015	100"	1525 x 2035	Video 4:3	19
1211515	115"	1755 x 2340	Video 4:3	22
1212015	120"	1830 x 2440	Video 4:3	23
1213015	130"	1980 x 2640	Video 4:3	26
1215015	150"	2285 x 3050	Video 4:3	30
1218015	180"	2745 x 3660	Video 4:3	35
1208425	84"	1046 x 1860	HDTV 16:9	16
1209225	92"	1145 x 2035	HDTV 16:9	17
1209625	96"	1195 x 2125	HDTV 16:9	18
1210025	100"	1245 x 2215	HDTV 16:9	19
1211525	115"	1430 x 2545	HDTV 16:9	22
1212525	125"	1555 x 2770	HDTV 16:9	24
1213025	130"	1615 x 2880	HDTV 16:9	25
1213525	135"	1680 x 2990	HDTV 16:9	26
1214025	140"	1740 x 3100	HDTV 16:9	27
1207265	72"	970 x 1550	16:10	13
1208465	84"	1130 x 1810	16:10	16
1209265	92"	1240 x 1980	16:10	17
1209665	96"	1295 x 2070	16:10	18
1210065	100"	1345 x 2155	16:10	19
1211065	110"	1480 x 2370	16:10	21
1212065	120"	1615 x 2585	16:10	23
1213065	130"	1750 x 2800	16:10	24
1214065	140"	1884 x 3015	16:10	27
1215065	150"	2020 x 3230	16:10	29
1218065	180"	2425 x 3880	16:10	34

For more information on the CinemaSnap Rear Pro please see our website or click here.

## CinemaSnap MICROPERF WHITE

As Micro Perforated screen material is acoustically transparent it is designed for speaker placement behind the screen, which allows for an accurate soundscape with centre speakers, with minimal interference of the acoustic performance.

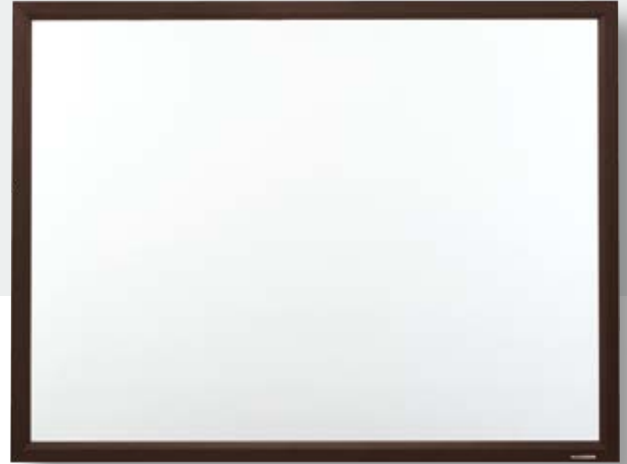

### BENEFITS

- Perfect lay flat
- Easy to install
- Contemporary design
- No moving parts

### APPLICATIONS

- Home Theatre
- Data Projection
- Boardroom Presentations
- Government Projects



### PRODUCT FEATURES

- Description:** Fixed Frame Screen - ready to assemble - best possible lay-flat qualities
- Frame:** Black Powdercoat Finish for Increased Contrast and Overscan Protection.
- Surface:** Easy snap on screen surface  
MicroPerf White - Gain 0.95  
Refer to page 5 for surface options
- Borders:** As per frame system - 80mm wide
- Brackets:** MultiTech Wall Brackets
- Sizes:** 72" Diagonal up to 150" Diagonal  
Custom Sizes & Formats available upon request.
- Options:** Flocke Frame Optional

Tech Drawing  
Hyperlink :



Custom Sizes & Formats available upon request.

Item No	Inch Diagonal	Image size mm	Format	Weight kg
1207213	72"	1100 x 1465	Video 4:3	16
1208413	84"	1280 x 1705	Video 4:3	17
1209613	96"	1460 x 1950	Video 4:3	18
1210013	100"	1525 x 2035	Video 4:3	19
1211513	115"	1755 x 2340	Video 4:3	22
1212013	120"	1830 x 2440	Video 4:3	23
1213013	130"	1980 x 2640	Video 4:3	26
1215013	150"	2285 x 3050	Video 4:3	30
1207223	72"	895 x 1595	HDTV 16:9	13
1208423	84"	1046 x 1860	HDTV 16:9	16
1209223	92"	1145 x 2035	HDTV 16:9	17
1209623	96"	1195 x 2125	HDTV 16:9	18
1210023	100"	1245 x 2215	HDTV 16:9	19
1211023	110"	1370 x 2435	HDTV 16:9	21
1211523	115"	1430 x 2545	HDTV 16:9	22
1212523	125"	1555 x 2770	HDTV 16:9	24
1213023	130"	1615 x 2880	HDTV 16:9	25
1213523	135"	1680 x 2990	HDTV 16:9	26
1215023	150"	1865 x 3320	HDTV 16:9	27
1218023	180"	2240 x 3985	HDTV 16:9	29
1207263	72"	715 x 1685	Cinemascope 2.35:1	17
1208463	84"	835 x 1965	Cinemascope 2.35:1	18
1209263	92"	915 x 2155	Cinemascope 2.35:1	19
1209663	96"	955 x 2245	Cinemascope 2.35:1	20
1210063	100"	995 x 2340	Cinemascope 2.35:1	22
1211063	110"	1095 x 2575	Cinemascope 2.35:1	23
1212063	120"	1195 x 2810	Cinemascope 2.35:1	25
1213063	130"	1295 x 3054	Cinemascope 2.35:1	26
1214063	140"	1395 x 3280	Cinemascope 2.35:1	28
1215063	150"	1495 x 3515	Cinemascope 2.35:1	30



For more information on the Micro Perf CinemaSnap please see our website or click here.

**CinemaSnap**

**FLOCKE FINISH FRAME**

The standard CinemaSnap frame has powder coat black ripple as a finish, but if you want a Deluxe finish on your frame, why not have it Flocked!

With a black velvet style finish this not only looks great but as a bonus it soaks up projector overscan better than the standard finish.

Item No 3500103



Flocke Finish



Painted Finish

**CinemaSnap**

**FREESTANDING T-LEGS**

Take the standard CinemaSnap fixed frame screen and bolt on these 'T' Legs and you have the perfect mobile presentation screen which can be moved from room to room where the occasional screen is required for conferences and training purposes.

Less complicated to erect and more economical than the traditional portable TechFold Screen, just remember you cannot pack it away in a roadcase when you are finished, it is more of an "on-premises" style screen solution.

Item No 3500104



**CinemaSnap**

**EYE BOLT INSTALLATION**

No wall to mount your CinemaSnap on, why not hang it from the ceiling?

A commonly used option in commercial applications, this method gives great flexibility in public spaces, theatrical and staging events. A minimum of 3 threaded nutserts are installed onto the top CinemaSnap rail and eye bolts are supplied to suit. **Note** - Oversized screens may require additional eyebolt fixing, seek advice.

Item No 3500105



Please seek advice from the sales office when using eye bolts with CinemaSnap XL.

For more information on the CinemaSnap Screens please see our website or click here.



## ViewMaster Pro Entry Level Motorised Screen



The ViewMaster has been pulled out of retirement and given a new lease on life. This entry level screen has been given a serious make over to meet today's high standards, providing a combination of cost conscious design and commercial features.

With IR, Contact Closure and 12v trigger as standard the ViewMaster Pro offers many of the control options needed in the audio visual environment.

The ViewMaster Pro offers multi-position brackets, both wall and ceiling for simple installation and is available with an optional in-ceiling screen box.

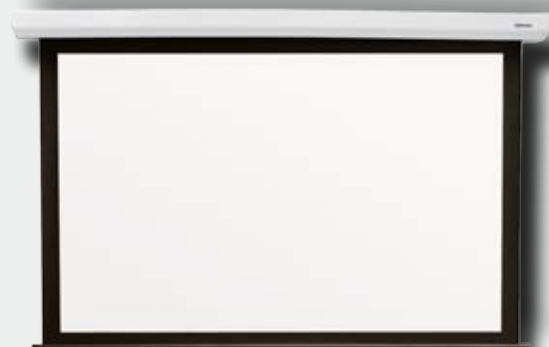

### BENEFITS

- Universal bracket system
- Quiet motor system, C Tick Approved
- Large diameter 63mm heavy duty roller, for improved layflat
- Premium slat rod design
- Integrated IR, Contact Closure control & 12v Trigger
- Designed in Australia to meet Australian design requirements
- Surface Fire Rated
- Low VOC water based black boarder paint



Item No	Inch Diagonal	Image Size mm	Format
4508419	84"	1280 x 1705	Video 4:3
4509619	96"	1465 x 1950	Video 4:3
4510019	100"	1525 x 2035	Video 4:3
4511019	110"	1676 x 2235	Video 4:3
4512019	120"	1830 x 2440	Video 4:3
4508429	84"	1045 x 1860	HDTV 16:9
4509629	96"	1195 x 2125	HDTV 16:9
4510029	100"	1245 x 2215	HDTV 16:9
4511029	110"	1370 x 2435	HDTV 16:9
4512029	120"	1495 x 2655	HDTV 16:9
4508469	84"	1130 x 1810	16:10
4509669	96"	1295 x 2070	16:10
4510069	100"	1345 x 2155	16:10
4511069	110"	1480 x 2370	16:10
4512069	120"	1615 x 2585	16:10

Please Note: This product is not suitable to be used in conjunction with a Short Throw Projector.

Custom Sizes & Formats available upon request.

### PRODUCT FEATURES

- Head Box: Powder Coat White as standard
- Surface: Unity White FG Screen - Gain 1.1  
Refer to page 5 for surface options
- Borders: 50mm Sides & Bottom with 300mm adjustable top black leader.
- Brackets: One piece clip-on L bracket suitable for wall or ceiling installation.
- Roller Diameter: 63mm Heavy Duty
- Sizes: 84" to 120" Custom Sizes, additional leaders & Formats available upon request.
- Options: Screen Box NB: not interchangeable with the ElectriCinema Screen Box.

Tech Drawing  
Hyperlink :

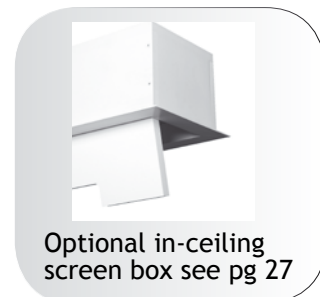
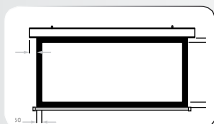

Optional in-ceiling screen box see pg 27

For more information on the ViewMaster Pro please see our website or click here.



## ViewMaster Pro SCREEN BOX



The ViewMaster Pro screen box allows you to install a ViewMaster Pro into the ceiling so that it is out of sight when not in use but instantly accessible.

With an integrated power junction box for electrical connection and a universal bracketing system for the screen, the screen box can be pre-fitted during the building construction stage.



### BENEFITS

- Pre-Wiring Facility
- Maintenance Access Door
- Single Trade Installation



### APPLICATIONS

- Home Theatre
- Boardroom Presentation
- Educational Facilities

### PRODUCT FEATURES

- Description:** In-Ceiling installation with power junction and brackets system.
- Box:** MDF Construction with fully painted Low VOC 2 pack white underside & ceiling edge covers for easy install. Custom colours available.
- Screen:** Suitable only for the ViewMaster Pro Range of Screens.
- Installation:** Utilising 8mm threaded holes with either brooker rod or eye bolts to suitable structure.
- Brackets:** Utilises brackets supplied with Viewmaster Pro Screen.
- Sizes:** As Shown, Custom Sizes & Formats available upon request.

Tech Drawing  
Hyperlink :

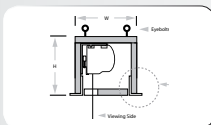

Item No	Size	Box Dimensions	Weight kg
VB4508419	84"	L-2000 x W-215 x H-175	30
VB4509619	96"	L-2260 x W-215 x H-175	32
VB4510019	100"	L-2430 x W-215 x H-175	33
VB4511019	110"	L-2520 x W-215 x H-175	46
VB4512019	120"	L-2605 x W-215 x H-175	48
VB4508429	84"	L-2820 x W-215 x H-175	30
VB4509629	96"	L-3035 x W-215 x H-175	34
VB4510029	100"	L-3250 x W-215 x H-175	35
VB4511029	110"	L-3465 x W-215 x H-175	46
VB4512029	120"	L-3680 x W-215 x H-175	48
VB4508469	84"	L-4330 x W-215 x H-175	30
VB4509669	96"	L-2000 x W-215 x H-175	33
VB4510069	100"	L-2260 x W-215 x H-175	35
VB4511069	110"	L-2430 x W-215 x H-175	45
VB4512069	120"	L-2520 x W-215 x H-175	48

Does not include projection screen.

**Please Note:** Not interchangeable with the ElectriCinema Screen Box.

Custom Sizes & Formats available upon request.

For more information on the ViewMaster Pro please see our website or click here.



## Lecturer COMMERCIAL MOTORISED SCREEN

The Plain Jane of the projection screen world, with basic wall switch operation and twin hanging points is perfect for auditoriums and halls who need a simple solution for a larger screen type.

This product has no integrated control but utilises a hard wired wall switch.



### BENEFITS

- Sizes 130" to 200" diagonal
- Superior lay flat
- Quiet operation



### APPLICATIONS

- Government Projects
- Boardroom Presentations
- Educational & Training

### PRODUCT FEATURES

- Head Box:** Steel Head Box in Powder Coat Matt Black - White Optional no charge.
- Surface:** Unity White FG up to 150" \*  
Unity White PVC above 150" \*  
Refer to page 5 for surface options
- Borders:** 50mm Sides & Bottom - (Square Format 40mm Sides & no top or bottom) & 300mm top black leader.
- Brackets:** Standard with Steel 8mm Eyebolts
- Sizes:** 130" Diagonal to 200" Diagonal.  
Custom Sizes & Formats available upon request.
- Roller Diameter:** 80mm Heavy Duty
- Options:** Flat Ceiling Brackets - Custom Colours  
- Extra Top Masking - RTS Remote.
- Top Leader:** 300mm standard, 600mm maximum optional upon request.

Tech Drawing  
Hyperlink :

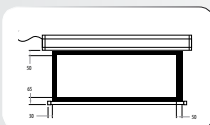

Item No	Inch Diagonal	Image Size mm	Format	Weight kg
0527509	n/a	2750 x 2750	Square	32
0530509	n/a	3050 x 3050	Square	35
0535509	n/a	3550 x 3550	Square	48
0541709	n/a	4170 x 4170	Square	55
0513019	130"	1980 x 2640	Video 4:3	29
0515019	150"	2285 x 3050	Video 4:3	33
0518019	180"	2745 x 3660	Video 4:3	46
0520019	200"	3050 x 4065	Video 4:3	52
0513029	130"	1615 x 2880	HDTV 16:9	30
0515029	150"	1865 x 3320	HDTV 16:9	38
0518029	180"	2240 x 3985	HDTV 16:9	50
0513069	130"	1750 x 2800	16:10	30
0514069	140"	1884 x 3015	16:10	33
0515069	150"	2020 x 3230	16:10	38
0518069	180"	2425 x 3880	16:10	50

Please Note: This product is not suitable to be used in conjunction with a Short Throw Projector.

Surface Fire Rated

Custom Sizes & Formats available upon request.

\*Only applies to standard screens.

For more information on the lecturer please see our website or click here.





## ElectriCinema

### HI CONTRAST GREY



The ElectriCinema has long been the premium projection screen of choice for the AV industry, with all the high quality features that you come to expect from a Screen Technics product, rugged design, contemporary good looks and ease of installation with the universal bracket system.

#### Control

Fully integrated with Connect IP, 12v trigger, contact closure and IR plus the ability to link & group switch with other Connect control devices

#### Why choose a Grey Screen ?

When you don't have full control of ambient light conditions the colour grey assists the projector in improving black levels in the colour spectrum by shifting the contrast band towards the darker scale. This improves overall colour saturation but with the loss of some brightness normally well compensated for by today's modern projectors.



#### PRODUCT FEATURES ELECTRICINEMA

- Description:** Designer Style Motorised Projection Screen with Integrated IP, 12v Trigger, contact closure & IR Remote Control.
- Head Box:** Powder Coat White as standard with Silver or Black as same cost option.
- Surface:** Hi Contrast Grey - Gain 0.8
- Borders:** 50mm Sides & Bottom with 300mm adjustable top black leader.
- Brackets:** One piece clip-on L bracket suitable for wall or ceiling installation.
- Sizes:** 72" Diagonal to 150" Diagonal. Custom Sizes & Formats available upon request.
- Roller Diameter:** Small Canister - 53mm Heavy Duty  
Large Canister - 80mm Heavy Duty
- Options:** Extra Top Masking - RF RTS Remote, custom powder coat colours.
- Top Leader:** For sizes 100" and under the maximum total top black leader available is 500mm, for screen sizes over 100" the maximum top black leader available is 600mm.

Tech Drawing  
Hyperlink :

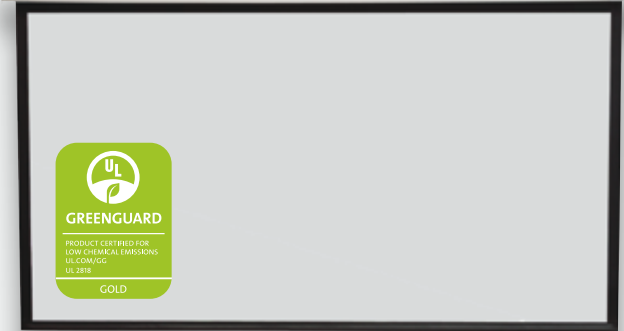
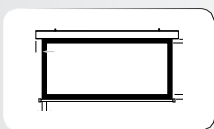

#### What is a Lambertian Screen ?

The Hi Contrast Grey has a maximum gain of 0.8 which by definition creates the Lambertian effect of a 180 degrees wide viewing cone, with little brightness drop off when viewed from an extreme angle. Perfectly suitable for public space installations with a wide audiences.

Surface Fire Rated

Item No	Inch Diagonal	Image Size mm	Format	Weight kg
0607218-S	72"	1100 x 1465	Video 4:3	14
0608418-S	84"	1280 x 1705	Video 4:3	17
0609618-S	96"	1465 x 1950	Video 4:3	18
0610018-S	100"	1525 x 2035	Video 4:3	19
0611518-L	115"	1755 x 2340	Video 4:3	31
0613018-L	130"	1980 x 2640	Video 4:3	34
0615018-L	150"	2285 x 3050	Video 4:3	39
0607228-S	72"	895 x 1595	HDTV 16:9	15
0608428-S	84"	1045 x 1860	HDTV 16:9	17
0609228-S	92"	1145 x 2035	HDTV 16:9	18
0609628-S	96"	1195 x 2125	HDTV 16:9	18.5
0610028-S	100"	1245 x 2215	HDTV 16:9	19
0611028-L	110"	1370 x 2435	HDTV 16:9	31
0611528-L	115"	1430 x 2545	HDTV 16:9	32
0612028-L	120"	1495 x 2655	HDTV 16:9	33
0613028-L	130"	1615 x 2880	HDTV 16:9	37
0615028-L	150"	1865 x 3320	HDTV 16:9	45.5
0607268-S	72"	970 x 1550	16:10	15
0608468-S	84"	1130 x 1810	16:10	17.5
0609268-S	92"	1240 x 1980	16:10	18
0609668-S	96"	1295 x 2070	16:10	18.5
0610068-S	100"	1345 x 2155	16:10	19
0611068-L	110"	1480 x 2370	16:10	31
0612068-L	120"	1615 x 2585	16:10	32
0613068-L	130"	1750 x 2800	16:10	35
0614068-L	140"	1885 x 3015	16:10	39
0615068-L	150"	2020 x 3230	16:10	44

Please Note: This product is not suitable to be used in conjunction with a Short Throw Projector.

For more information on the ElectriCinema Screens please see our website or click here.



## ElectriCinema PREMIUM MOTORISED SCREEN



Please Note: This product is not suitable to be used in conjunction with a Short Throw Projector.

Surface Fire Rated



The ElectriCinema has long been the premium projection screen of choice for the AV industry, with all the high quality features that you come to expect from a Screen Technics product, rugged design, contemporary good looks and ease of installation with the universal bracket system.

### Control

Full integrated with Connect IP, 12v trigger, contact closure and IR plus the ability to link & group switch with other Connect control devices

### PRODUCT FEATURES ELECTRICINEMA

- Description:** Designer Style Motorised Projection Screen with Integrated IP, 12v Trigger, contact closure & IR Remote Control.
- Head Box:** Powder Coat White as standard with Silver or Black as same cost option.
- Surface:** Unity White FG up to 150" \*  
Unity White PVC above 150" \*  
Refer to page 5 for surface options
- Borders:** 50mm Sides & Bottom with 300mm adjustable top black leader.
- Brackets:** One piece clip-on L bracket suitable for wall or ceiling installation.
- Sizes:** 72" Diagonal to 300" Diagonal. Custom Sizes & Formats available upon request.
- Roller Diameter:** Small Canister - 53mm Heavy Duty  
Large Canister - 80mm Heavy Duty
- Options:** ChromaKey Surface , Extra Top Masking, RF RTS Remote, custom powder coat colours.
- Top Leader:** For sizes 100" and under the maximum total top black leader available is 500mm, for screen sizes over 100" the maximum top black leader available is 600mm.

Tech Drawing  
Hyperlink :

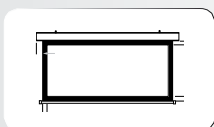

- \* Only applies to standard screens.
- Not GreenGuard certified this size

For more information on the ElectriCinema Screens please see our website or click here.

Item No	Inch Diagonal	Image Size mm	Format	Weight kg
0607219-S	72"	1100 x 1465	Video 4:3	14
0608419-S	84"	1280 x 1705	Video 4:3	17
0609619-S	96"	1465 x 1950	Video 4:3	18
0610019-S	100"	1525 x 2035	Video 4:3	19
0611519-L	115"	1755 x 2340	Video 4:3	31
0613019-L	130"	1980 x 2640	Video 4:3	34
0615019-L	150"	2285 x 3050	Video 4:3	39
0618019-L	180"	2745 x 3660	Video 4:3	52
0620019-L	200"	3050 x 4065	Video 4:3	62
0607229-S	72"	895 x 1595	HDTV 16:9	15
0608429-S	84"	1045 x 1860	HDTV 16:9	17
0609229-S	92"	1145 x 2035	HDTV 16:9	18
0609629-S	96"	1195 x 2125	HDTV 16:9	18.5
0610029-S	100"	1245 x 2215	HDTV 16:9	19
0611029-L	110"	1370 x 2435	HDTV 16:9	31
0611529-L	115"	1430 x 2545	HDTV 16:9	32
0612029-L	120"	1495 x 2655	HDTV 16:9	33
0613029-L	130"	1615 x 2880	HDTV 16:9	37
0615029-L	150"	1865 x 3320	HDTV 16:9	45.5
0616029-L	160"	1995 x 3545	HDTV 16:9	50
0617029-L	170"	2115 x 3765	HDTV 16:9	56
0618029-L	180"	2240 x 3985	HDTV 16:9	61
0607269-S	72"	970 x 1550	16:10	15
0608469-S	84"	1130 x 1810	16:10	17.5
0609269-S	92"	1240 x 1980	16:10	18
0609669-S	96"	1295 x 2070	16:10	18.5
0610069-S	100"	1345 x 2155	16:10	19
0611069-L	110"	1480 x 2370	16:10	31
0612069-L	120"	1615 x 2585	16:10	32
0613069-L	130"	1750 x 2800	16:10	35
0614069-L	140"	1885 x 3015	16:10	39
0615069-L	150"	2020 x 3230	16:10	44
0616069-L	160"	2155 x 3450	16:10	50
0617069-L	170"	2290 x 3665	16:10	56
0618069-L	180"	2425 x 3878	16:10	61



## ElectriCinema XL

### PREMIUM MOTORISED SCREEN

In 2012 Screen Technics released the ElectriCinema XL into the market. Up till then if you required a screen larger than 200" diagonal, you had to deal with our Chancellor range of screens, which was a basic heavy duty staging product, but now with the XL series you can expect all the designer good looks and leading edge functionality that the ElectriCinema is justly famous for. These features include the internally mounted Connect Motor Control device with integrated IP, 12v trigger, contact closure & IR remote control and flexible bracketing system.

Since its release the ElectriCinema XL has dominated the market and continues to be screen of choice for any large venue.

#### BENEFITS

- Sizes up to 300" Diagonal.
- Adjustable pick up point locations
- Connect Control System with IP, 12v Trigger. IR Control and contact close.
- Designer Good Looks.
- Surface Fire Rated



#### APPLICATIONS

- Home Theatre
- Boardroom Presentations
- Educational & Training Facilities

#### PRODUCT FEATURES ELECTRICINEMA XL

- Description:** Designer Style Motorised Projection Screen with Integrated IP, 12v Trigger, contact closure & IR Remote Control.
- Head Box:** Colour to be specified at time of order, standard powder Coat options are White, Silver or Black. Custom colours are available upon request.
- Surface:** Unity White PVC - Gain 1.0  
Refer to page 5 for surface options
- Borders:** 50mm Sides & Bottom with adjustable top black leader. Leader length needs to be specified at time of order.
- Brackets:** Load Rated M10 Eyebolts
- Sizes:** 200" Diagonal to 300" Diagonal.  
Custom Sizes & Formats available upon request.
- Roller Diameter:** 150mm Heavy Duty
- Options:** Extra Top Masking - RF  
RTS Remote or 4 Core Wall  
Switch, custom powder coat colour.  
To be specified at time of order.
- Top Leader:**

Tech Drawing  
Hyperlink :

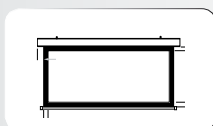

Item No	Inch Diagonal	Image Size mm	Format	Weight kg
0622519-XL	225"	3430 x 4570	Video 4:3	145
0625019-XL	250"	3810 x 5080	Video 4:3	160
0627519-XL	275"	4190 x 5590	Video 4:3	170
0630019-XL	300"	4570 x 6100	Video 4:3	185
0620029-XL	200"	2490 x 4425	HDTV 16:9	140
0622529-XL	225"	2800 x 4980	HDTV 16:9	155
0625029-XL	250"	3115 x 5535	HDTV 16:9	170
0627529-XL	275"	3425 x 6085	HDTV 16:9	185
0620069-XL	200"	2695 x 4310	16:10	140
0622569-XL	225"	3030 x 4850	16:10	150
0625069-XL	250"	3365 x 5385	16:10	165
0627569-XL	275"	3705 x 5925	16:10	180

Custom Sizes & Formats available upon request.

Not to be used in conjunction with the ElectriCinema Screen Box.

Due to the size and weight of this product freight costs can be significant, please allow for this in your tendering process.

Please Note: This product is not suitable to be used in conjunction with a Short Throw Projector.

The ElectriCinema XL utilise load rated M10 Eyebolts and requires at least 6 fixing points.



For more information on the ElectriCinema XL Screens please see our website or click here.

## Large Commercial ADMIRAL

For projects that require a motorised screen with an image width greater than 6100mm, the bottom roller design gives the best possible lay flat for these challenging installations.

Site requirements normally dictate the use of a custom size screen in these larger venues. Please seek advice from the sales department.

Due to the size and weight of this product freight costs can be significant, please allow for this in your tendering process.

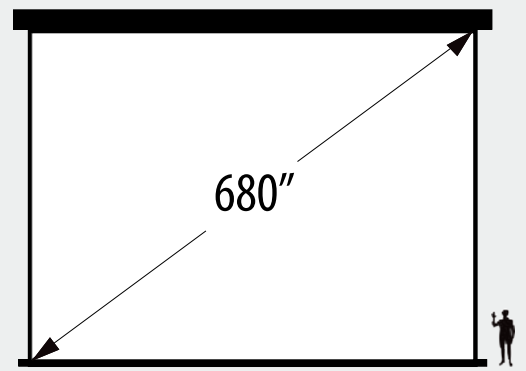

### BENEFITS

- Bottom roller design
- Steel box frame construction
- Custom sizes and formats available
- Surface Fire Rated



### APPLICATIONS

- 6100mm to 13800mm in width
- Multi purpose rooms
- Conference Rooms
- Educational Facilities



P1000 Uni-Strut Bracket System

### PRODUCT FEATURES

- Description:** Large Commercial motorised screen
- Head Box:** Matt Black.
- Surface:** Unity White PVC - Gain 1.0  
Refer to page 5 for surface options
- Borders:** 50mm Sides & 200mm Bottom, top leader length needs to be specified at time of order.
- Brackets:** P1000 Uni-Strut Bracket System
- Sizes:** 350" Diagonal to 550" Diagonal.  
Custom Sizes & Formats available upon request.
- Roller Diameter:** 150mm Heavy Duty
- Options:** Extra Top Masking, Connect Control, custom powder coat colours.
- Top Leader:** To be specified at time of order.
- Tech Drawing**
- Hyperlink :**

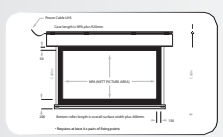

Item No	Inch Diagonal	Image Size mm	Format	Weight kg
0965009	n/a	6500 x 6500	Square	310
0970009	n/a	7000 x 7000	Square	330
0980009	n/a	8000 x 8000	Square	370
0935019	350"	5330 x 7110	Video 4:3	335
0940019	400"	6100 x 8130	Video 4:3	380
0945019	450"	6860 x 9150	Video 4:3	420
0950019	500"	7620 x 10160	Video 4:3	460
0955019	550"	8380 x 11180	Video 4:3	500
0960019	600"	4064 x 12192	Video 4:3	540
0968019	680"	10350 x 13800	Video 4:3	620
0930029	300"	3735 x 6641	HDTV 16:9	315
0935029	350"	4355 x 7745	HDTV 16:9	360
0940029	400"	4980 x 8855	HDTV 16:9	410
0950029	500"	6225 x 11065	HDTV 16:9	500
0955029	550"	6850 x 12175	HDTV 16:9	545
0960029	600"	7470 x 13280	HDTV 16:9	580
0962029	620"	7720 x 13725	HDTV 16:9	600
0930069	300"	4040 x 6464	16:10	300
0935069	350"	4715 x 7540	16:10	350
0940069	400"	5385 x 8620	16:10	400
0950069	500"	6735 x 10775	16:10	485
0955069	550"	7405 x 11850	16:10	530
0960069	600"	8080 x 12930	16:10	570
0964069	640"	8620 x 13790	16:10	600

**Please Note:** This product is not suitable to be used in conjunction with a Short Throw Projector.

Custom Sizes & Formats available upon request.



For more information on the Admiral Screen please see our website or click here.

## ElectriCinema SCREEN BOX



### BENEFITS

- Pre-Wiring Facility
- Maintenance Access Door
- Single Trade Installation

### APPLICATIONS

- Home Theatre
- Boardroom Presentation
- Educational Facilities



Does not include projection screen.

### PRODUCT FEATURES

- Description:** In-Ceiling installation with power junction and brackets system.
- Box:** MDF Construction with fully painted Low VOC 2 pack white underside & ceiling edge covers for easy install. Custom colours available.
- Screen:** Suitable only for ElectriCinema Range of Screens.
- Installation:** Utilising 8mm threaded holes with either brooker rod or eye bolts to suitable structure.
- Brackets:** Utilises brackets supplied with ElectriCinema Screen.
- Sizes:** As shown - Custom Sizes & Formats available upon request. - Also Side Tension Screens in Large Style.
- Options:** Suitable for Side Tension Systems upon request - size restrictions apply. Not available for the ElectriCinema XL range.

Tech Drawing  
Hyperlink :

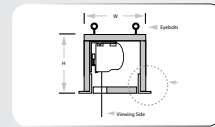

Item No	Size	Box Dimensions (mm)	Weight kg
EB607219-S	72" 4:3	L-1960 x W-195 x H-160	28
EB608419-S	84" 4:3	L-2200 x W-195 x H-160	30
EB609619-S	96" 4:3	L-2445 x W-195 x H-160	32
EB610019-S	100" 4:3	L-2530 x W-195 x H-160	33
EB611519-L	115" 4:3	L-2835 x W-235 x H-200	44
EB613019-L	130" 4:3	L-3135 x W-235 x H-200	49
EB615019-L	150" 4:3	L-3545 x W-235 x H-200	55
EB618019-L	180" 4:3	L-4155 x W-235 x H-200	70
EB607229-S	72" 16:9	L-2090 x W-195 x H-160	28
EB608429-S	84" 16:9	L-2355 x W-195 x H-160	30
EB609229-S	92" 16:9	L-2530 x W-195 x H-160	33
EB609629-S	96" 16:9	L-2620 x W-195 x H-160	34
EB610029-S	100" 16:9	L-2710 x W-195 x H-160	35
EB611029-L	110" 16:9	L-2930 x W-235 x H-200	46
EB611529-L	115" 16:9	L-3040 x W-235 x H-200	47
EB612029-L	120" 16:9	L-3150 x W-235 x H-200	48
EB613029-L	130" 16:9	L-3375 x W-235 x H-200	51
EB615029-L	150" 16:9	L-3815 x W-235 x H-200	61
EB616029-L	160" 16:9	L-4040 x W-235 x H-200	66
EB617029-L	170" 16:9	L-4260 x W-235 x H-200	71
EB618029-L	180" 16:9	L-4480 x W-235 x H-200	76

Item No	Size	Box Dimensions (mm)	Weight kg
EB607269-S	72" 16:10	L-2045 x W-195 x H-160	28
EB608469-S	84" 16:10	L-2305 x W-195 x H-160	30
EB609269-S	92" 16:10	L-2475 x W-195 x H-160	32
EB609669-S	96" 16:10	L-2565 x W-195 x H-160	33
EB610069-S	100" 16:10	L-2650 x W-195 x H-160	35
EB611069-L	110" 16:10	L-2865 x W-235 x H-200	45
EB612069-L	120" 16:10	L-3080 x W-235 x H-200	48
EB613069-L	130" 16:10	L-3295x W-235 x H-200	51
EB614069-L	140" 16:10	L-3510 x W-235 x H-200	56
EB615069-L	150" 16:10	L-3725 x W-235 x H-200	61
EB616029-L	160" 16:10	L-3945 x W-235 x H-200	66
EB617029-L	170" 16:10	L-4160x W-235 x H-200	71
EB618069-L	180" 16:10	L-4373 x W-235 x H-200	75

Please note **L** stands for Large Box Style and **S** stands for Small Box Style. Interfit Box can be used for Side Tension ElectriCinema in **L** Box only - Dimensions on application.

Custom Sizes & Formats available upon request.

**Please Note:** Not interchangeable with the ViewMaster Pro Screen Box.

For more information on the ElectriCinema Screen Box please see our website or click here.



## ElectriCinema SIDE TENSION

The Side Tension system offers the ultimate experience in a motorised projection screen, providing the best possible lay flat with its large diameter roller and side tensioning system to pull the screen flat, suitable for home theatre.

### Control

Fully integrated with Connect IP, 12v trigger, contact closure and IR plus the ability to link & group switch with other Connect control devices

### BENEFITS

- Excellent lay flat
- Quiet operation
- Reliability



### APPLICATIONS

- Home Theatre
- Boardroom Presentations
- Data Projection

### PRODUCT FEATURES

- Description:** Designer Style Motorised Projection Screen with Integrated IR Remote Control.
- Head Box:** Powder Coat White as standard with Silver and Black available.
- Surface:** Unity White PVC - Gain 1.0  
Refer to page 5 for surface options
- Borders:** 50mm Sides & Bottom with 300mm adjustable top black leader.
- Brackets:** One piece clip-on L bracket suitable for wall or ceiling installation.
- Sizes:** As per the adjacent listing. Custom Sizes & Formats available upon request.
- Roller Diameter:** 80mm Heavy Duty
- Options:** Extra Top leader
- Tech Drawing Hyperlink :**   **N17821**

Please Note: This product is not suitable to be used in conjunction with a Short Throw Projector.



Item No	Inch Diagonal	Image mm	Format
0607211-L	72"	1100 x 1465	Video 4:3
0608411-L	84"	1280 x 1705	Video 4:3
0609611-L	96"	1465 x 1950	Video 4:3
0610011-L	100"	1525 x 2035	Video 4:3
0611511-L	115"	1755 x 2340	Video 4:3
0613011-L	130"	1980 x 2640	Video 4:3
0615011-L	150"	2285 x 3050	Video 4:3
0618011-L	180"	2745 x 3660	Video 4:3
0608421-L	84"	1045 x 1860	HDTV 16:9
0609221-L	92"	1145 x 2035	HDTV 16:9
0609621-L	96"	1195 x 2125	HDTV 16:9
0610021-L	100"	1245 x 2215	HDTV 16:9
0611021-L	110"	1370 x 2435	HDTV 16:9
0611521-L	115"	1430 x 2545	HDTV 16:9
0612021-L	120"	1495 x 2655	HDTV 16:9
0613021-L	130"	1615 x 2880	HDTV 16:9
0615021-L	150"	1865 x 3320	HDTV 16:9
0618021-L	180"	2240 x 3985	HDTV 16:9
0608461-L	84"	1130 x 1810	16:10
0609261-L	92"	1240 x 1980	16:10
0609661-L	96"	1295 x 2070	16:10
0610061-L	100"	1345 x 2155	16:10
0611061-L	110"	1480 x 2370	16:10
0612061-L	120"	1615 x 2585	16:10
0613061-L	130"	1750 x 2800	16:10
0614061-L	140"	1884 x 3015	16:10
0615061-L	150"	2020 x 3230	16:10
0618061-L	180"	2425 x 3880	16:10

Custom Sizes & Formats available upon request.

For more information on the ElectriCinema Side Tension Screen please see our website or click here.

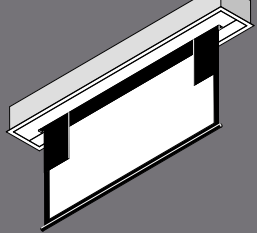

## ElectriCinema 235 IN-CEILING SCREEN WITH SIDE MASKING

Designed to work with projectors that utilises Anamorphic Lens technology.

The ElectriCinema 235 you can have the best of both worlds, 2.35:1 Cinemascope for DVD movies and by utilizing the motorised side masking system, reshape the screen to 16:9 HDTV for widescreen TV broadcasts.

Supplied as an integrated in-ceiling solution, with fully paint finished underside, and ceiling edge trims for a single trade install.

With the industry leading CONNECT control system as a standard inclusion, allowing IR control or contact close for integration with control systems, plus the ability to link with other CONNECT devices, such as projector lifts or roller blind systems, this screen has all the bells and whistles.



### BENEFITS

- Original Movie Aspect Ratio 2.35:1
- Integrated Side Masking for 16:9
- One Piece In-Ceiling Design
- Flush Sitting Masking with no shadow-line



### APPLICATIONS

- Home Theatre

### PRODUCT FEATURES

**Description:** In-ceiling screen system with side masking for dual format Cinemascope to HDTV formats.

**Head Box:** MDF constructions with fully painted white underside & ceiling edge covers for easy install.

**Surface:** Radial Cut Edge Unity White PVC Gain 1.0, Refer to page 5 for surface options

**Borders:** 50mm Sides & Bottom with 500mm adjustable top black leader.

**Sizes:** 84" to 150" Diagonally, Custom Sizes & Formats available upon request.

**Roller Diameter:** 80mm Heavy Duty

**Options:** Side Tension, Extra Top Masking, Underside Paint Colours.

**Top Leader:** For sizes 100" and under the maximum total top black leader available is 500mm, for screen sizes over 100" the maximum top black leader available is 600mm.

Tech Drawing  
Hyperlink :

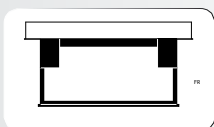

Item No	Inch Diagonal	Image Size 2.35:1	Image Size 16:9	Weight kg
5608449	84"	835 x 1965	835 x 1485	80
5609249	92"	915 x 2155	915 x 1625	85
5609649	96"	955 x 2245	955 x 1700	90
5610049	100"	995 x 2340	995 x 1770	95
5611049	110"	1095 x 2575	1095 x 1950	100
5612049	120"	1195 x 2810	1195 x 2125	110
5613049	130"	1295 x 3045	1295 x 2305	115
5614049	140"	1395 x 3280	1395 x 2480	125
5615049	150"	1495 x 3515	1495 x 2660	130

Also available in alternate CinemaScope format, e.g 2.40:1 / 2.37:1

**Please Note: This product is not suitable to be used in conjunction with a Short Throw Projector.**

Custom Sizes & Formats available upon request.

For more information on the ElectriCinema 235 Screen please see our website or click here.



## Trapdoor

### INTEGRATED IN-CEILING SCREEN

The ultimate way for your screen to be installed in the ceiling! Out of sight until it's time to go to the movies, your screen will magically roll down from the ceiling at the push of a button! With a self closing trapdoor mechanism and fully finished with Interfit ceiling edge cover strip and underside in low sheen white, the Trapdoor Projection screen is an easily fitted, single trade installation unit.

With the industry leading CONNECT control system as a standard inclusion, allowing IR control or contact close for integration with control systems, plus the ability to link with other CONNECT devices, such as projector lifts or roller blind systems, this screen has all the bells and whistles.

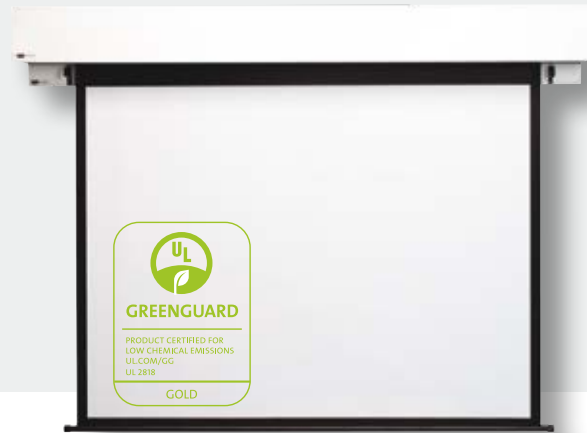

#### BENEFITS

- Hidden Installation
- Quiet Operation
- Automatic Door
- Simple Single Trade Installation



#### APPLICATIONS

- Home Theatre
- Boardroom Presentation
- Educational Facilities

#### PRODUCT FEATURES

- Description:** Fully Integrated in Ceiling Screen.
- Head Box:** Painted MDF with Self Closing Door.
- Surface:** Unity White FG - Gain 1.1  
Refer to page 5 for surface options
- Borders:** 50mm sides & 300mm Top Leader.
- Brackets:** Captive Nuts 8mm.
- Sizes:** 72" to 140" Diagonal.  
Custom Sizes & Formats available upon request.
- Roller Diameter:** 80mm Heavy Duty
- Options:** Side Tension - Extra Top Masking various control options available.
- Top Leader:** For sizes 100" and under the maximum total top black leader available is 500mm, for screen sizes over 100" the maximum top black leader available is 600mm.

Tech Drawing  
Hyperlink :

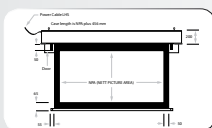

Item No	Inch Diagonal	Image Size mm	Format	Weight kg
3708419	84"	1280 x 1705	Video 4:3	50
3709619	96"	1465 x 1950	Video 4:3	54
3710019	100"	1525 x 2035	Video 4:3	56
3711519	115"	1755 x 2340	Video 4:3	62
3712519	125"	1905 x 2540	Video 4:3	66
3713019	130"	1980 x 2640	Video 4:3	68
3715019	150"	2285 x 3050	Video 4:3	76
3708429	84"	1045 x 1860	HDTV 16:9	52
3709229	92"	1145 x 2035	HDTV 16:9	56
3709629	96"	1195 x 2125	HDTV 16:9	58
3710029	100"	1245 x 2215	HDTV 16:9	40
3711529	115"	1430 x 2545	HDTV 16:9	66
3712529	125"	1555 x 2770	HDTV 16:9	70
3713029	130"	1615 x 2880	HDTV 16:9	72
3715029	150"	1865 x 3320	HDTV 16:9	78

Please Note: This product is not suitable to be used in conjunction with a Short Throw Projector.

Custom Sizes & Formats available upon request.

Surface Fire Rated



For more information on the Trapdoor Screen please see our website or click here.



## Trapdoor

### WITH SIDE TENSION - For the Ultimate Lay-flat

The ultimate way for your screen to be installed in the ceiling! Out of sight until it's time to go to the movies, your screen will magically roll down from the ceiling at the push of a button! With a self closing trapdoor mechanism and fully finished with Interfit ceiling edge cover strip and underside in low sheen white, the Trapdoor Projection screen is an easily fitted, single trade installation unit.

With the industry leading CONNECT control system as a standard inclusion, allowing IR control or contact close for integration with control systems, plus the ability to link with other CONNECT devices, such as projector lifts or roller blind systems, this screen has all the bells and whistles.

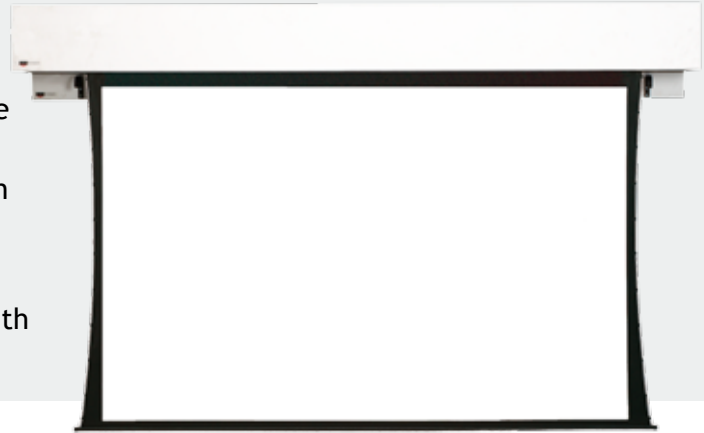

#### BENEFITS

- Hidden Installation
- Quiet Operation
- Automatic Door
- Simple Single Trade Installation



#### APPLICATIONS

- Home Theatre
- Boardroom Presentation
- Educational Facilities

Item No	Inch Diagonal	Image Size mm	Format
3708411	84"	1280 x 1705	Video 4:3
3709611	96"	1465 x 1950	Video 4:3
3710011	100"	1525 x 2035	Video 4:3
3711511	115"	1755 x 2340	Video 4:3
3712511	125"	1905 x 2540	Video 4:3
3713011	130"	1980 x 2640	Video 4:3
3715011	150"	2285 x 3050	Video 4:3
3708421	84"	1045 x 1860	HDTV 16:9
3709221	92"	1145 x 2035	HDTV 16:9
3709621	96"	1195 x 2125	HDTV 16:9
3710021	100"	1245 x 2215	HDTV 16:9
3711521	115"	1430 x 2545	HDTV 16:9
3712521	125"	1555 x 2770	HDTV 16:9
3713021	130"	1615 x 2880	HDTV 16:9
3715021	150"	1865 x 3320	HDTV 16:9

Please Note: This product is not suitable to be used in conjunction with a Short Throw Projector.

Custom Sizes & Formats available upon request.

#### PRODUCT FEATURES

- Description:** Fully Integrated in Ceiling Screen.
- Head Box:** Painted MDF with Self Closing Door.
- Surface:** Unity White PVC - Gain 1.0  
Refer to page 5 for surface options
- Borders:** 50mm sides & 300mm Top Leader.
- Brackets:** Captive Nuts 8mm.
- Sizes:** 72" to 140" Diagonal.  
Custom Sizes & Formats available upon request.
- Roller Diameter:** 80mm Heavy Duty
- Options:** Extra Top Masking  
various control options available.
- Top Leader:** Please seek advice from the sales office.

Tech Drawing  
Hyperlink :

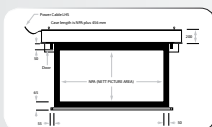

For more information on the Trapdoor Side Tension Screen please see our website or click here.

## Screen Lowering Device FOR ELECTRICINEMA SCREENS

What do you do if you have a very high ceiling, say in a Church or Town Hall? You lower the actual projection screen into position, then motor down the screen.

Utilising a secondary motor system that lowers and raises an ElectriCinema projection screen into position, it comes with a top enclosure for the screen to rest in when not in use and full cable management for both the primary screen and secondary lift motor.

Fully integrated with Connect contact closure and IR plus the ability to link & group switch with other Connect control devices



### BENEFITS

- Lowers the screen into position
- Screen Enclosure
- Back Up Fall Arrester for additional safety.
- System includes screen

### APPLICATIONS

- Town Halls
- Churches
- Educational Facilities
- Buildings with high ceilings



### PRODUCT FEATURES

- Description:** Lifting Device to lower motorised screen into position with high ceiling.
- Box:** MDF Construction with Ceiling Edge Strip and Cable Management System.
- Screen:** Pricing includes the cost of the Motorised Screen (ElectriCinema).
- Surface:** Unity White FG - Gain 1.1  
Refer to page 5 for surface options
- Travel:** Standard Travel Equals Picture Area Width (extra travel available POA).
- Sizes:** 72" to 180" Diagonal Custom Sizes & Formats available upon request.
- Brackets:** 8 off Captive Nuts 8mm.
- Options:** Extra Travel and various control options

Tech Drawing  
Hyperlink :

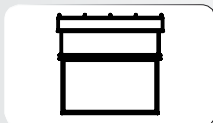

**Please Note:** This product is not suitable to be used in conjunction with a Short Throw Projector.

Item No	Inch Diagonal	Image Size mm	Format
SLD607219-S	72"	1100 x 1465	Video 4:3
SLD608419-S	84"	1280 x 1705	Video 4:3
SLD609619-S	96"	1465 x 1950	Video 4:3
SLD610019-S	100"	1525 x 2035	Video 4:3
SLD611519-L	115"	1755 x 2340	Video 4:3
SLD613019-L	130"	1980 x 2640	Video 4:3
SLD615019-L	150"	2285 x 3050	Video 4:3
SLD618019-L	180"	2745 x 3660	Video 4:3
SLD607229-S	72"	895 x 1595	HDTV 16:9
SLD608429-S	84"	1045 x 1860	HDTV 16:9
SLD609229-S	92"	1145 x 2035	HDTV 16:9
SLD609629-S	96"	1195 x 2125	HDTV 16:9
SLD610029-S	100"	1245 x 2215	HDTV 16:9
SLD611029-L	110"	1370 x 2435	HDTV 16:9
SLD611529-L	115"	1430 x 2545	HDTV 16:9
SLD612029-L	120"	1495 x 2655	HDTV 16:9
SLD613029-L	130"	1615 x 2880	HDTV 16:9
SLD615029-L	150"	1865 x 3320	HDTV 16:9
SLD618029-L	180"	2240 x 3985	HDTV 16:9
SLD607269-S	72"	970 x 1550	16:10
SLD608469-S	84"	1130 x 1810	16:10
SLD609269-S	92"	1240 x 1980	16:10
SLD609669-S	96"	1295 x 2070	16:10
SLD610069-S	100"	1345 x 2155	16:10
SLD611069-L	110"	1480 x 2370	16:10
SLD612069-L	120"	1615 x 2585	16:10
SLD613069-L	130"	1750 x 2800	16:10
SLD614069-L	140"	1885 x 3015	16:10
SLD615069-L	150"	2020 x 3230	16:10
SLD618069-L	180"	2425 x 3878	16:10

Surface Fire Rated

Custom Sizes & Formats available upon request.

For more information on the Screen Lowering Device please see our website or click here.



## Screen Lowering Device With Trapdoor FOR ELECTRICINEMA SCREENS

What do you do if you have a very high ceiling, say in a Church or Town Hall? You lower the actual projection screen into position, then motor down the screen.

Utilising a secondary motor system that lowers and raises an ElectriCinema projection screen into position, it comes with a top enclosure for the screen to rest in when not in use and full cable management for both the primary screen and secondary lift motor.

Fully integrated with Connect contact closure and IR plus the ability to link & group switch with other Connect control devices



### BENEFITS

- Lowers the screen into position
- Screen Enclosure
- Back Up Fall Arrester for additional safety.
- System includes screen



### APPLICATIONS

- Town Halls
- Churches
- Educational Facilities
- Buildings with high ceilings

### PRODUCT FEATURES

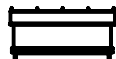
- Description:** Lifting Device to lower motorised screen into position with high ceiling.
- Box:** MDF Construction with Ceiling Edge Strip and Cable Management System & Self-Closing Door.
- Screen:** Pricing includes the cost of the Motorised Screen (ElectriCinema).
- Surface:** Unity White FG - Gain 1.1  
Refer to page 5 for surface options
- Travel:** Standard Travel Equals Picture Area Width (extra travel available POA).
- Sizes:** 72" to 180" Diagonal Custom Sizes & Formats available upon request.
- Brackets:** 8 off Captive Nuts 8mm.
- Options:** Extra Travel and various control options
- Tech Drawing Hyperlink :** 

Please Note: This product is not suitable to be used in conjunction with a Short Throw Projector.

Item No	Inch Diagonal	Image Size mm	Format
SLD3707219-S	72"	1100 x 1465	Video 4:3
SLD3708419-S	84"	1280 x 1705	Video 4:3
SLD3709619-S	96"	1465 x 1950	Video 4:3
SLD3710019-S	100"	1525 x 2035	Video 4:3
SLD3711519-L	115"	1755 x 2340	Video 4:3
SLD3713019-L	130"	1980 x 2640	Video 4:3
SLD3715019-L	150"	2285 x 3050	Video 4:3
SLD3718019-L	180"	2745 x 3660	Video 4:3
SLD3707229-S	72"	895 x 1595	HDTV 16:9
SLD3708429-S	84"	1045 x 1860	HDTV 16:9
SLD3709229-S	92"	1145 x 2035	HDTV 16:9
SLD3709629-S	96"	1195 x 2125	HDTV 16:9
SLD3710029-S	100"	1245 x 2215	HDTV 16:9
SLD3711029-L	110"	1370 x 2435	HDTV 16:9
SLD3711529-L	115"	1430 x 2545	HDTV 16:9
SLD3712029-L	120"	1495 x 2655	HDTV 16:9
SLD3713029-L	130"	1615 x 2880	HDTV 16:9
SLD3715029-L	150"	1865 x 3320	HDTV 16:9
SLD3718029-L	180"	2240 x 3985	HDTV 16:9
SLD3707269-S	72"	970 x 1550	16:10
SLD3708469-S	84"	1130 x 1810	16:10
SLD3709269-S	92"	1240 x 1980	16:10
SLD3709669-S	96"	1295 x 2070	16:10
SLD3710069-S	100"	1345 x 2155	16:10
SLD3711069-L	110"	1480 x 2370	16:10
SLD3712069-L	120"	1615 x 2585	16:10
SLD3713069-L	130"	1750 x 2800	16:10
SLD3714069-L	140"	1885 x 3015	16:10
SLD3715069-L	150"	2020 x 3230	16:10
SLD3718069-L	180"	2425 x 3878	16:10

Surface Fire Rated

For more information on the Screen Lowering Device with Trap Door please see our website or click here.

Custom Sizes & Formats available upon request.

