



# DNH

HEAD OFFICE, NORWAY

**DNH AS**

Phone..... + 47 35 98 56 00

Fax..... + 47 35 98 56 10

E-mail..... dnh@dnh.no

Web-Site..... www.dnh.no

ENGLAND

**DNH WW Ltd**

Phone..... + 44 1908 275 000

Fax..... + 44 1908 275 100

E-mail..... dnh@dnh.co.uk

GERMANY

**DNH GmbH**

Phone... + 49 040 6569 30-0

Fax..... + 49 040 6569 30-30

E-mail..... dnh@dnh.de

## BIVEP-6(T)

USA

**DNH Speakers Inc**

Phone..... + 1 484 494 5790

Fax..... + 1 484 494 5793

E-mail..... dnh@dnhspeakers.com

ISO 9001 CERTIFIED

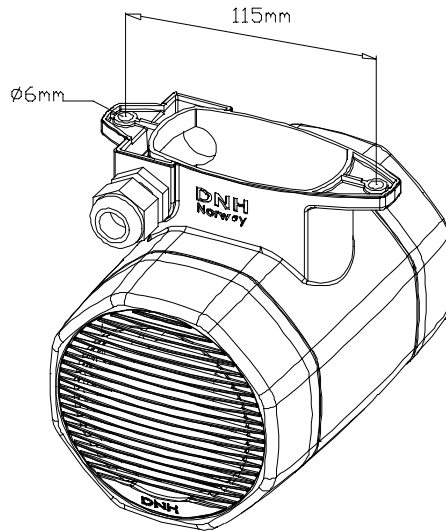
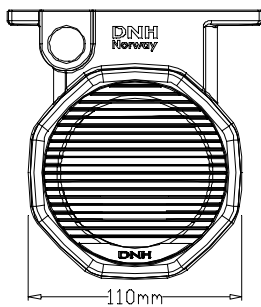
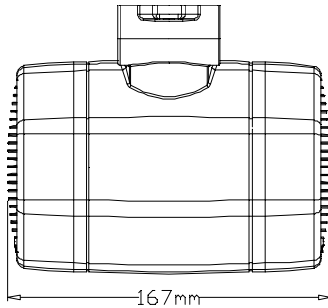

1xM20 blinding plug  
1xM20 gland

Circuit diagram

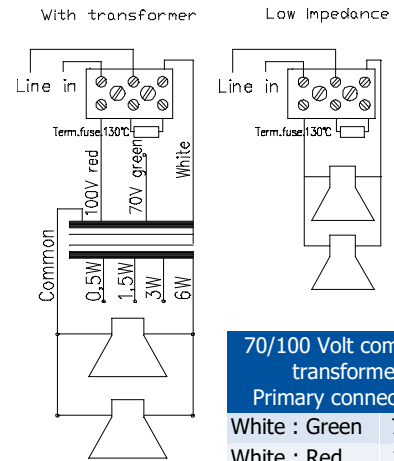

70/100 Volt combined transformer Primary connections	
White : Green	70 V
White : Red	100 V
Secondary nominal tapings	
C : 6	6,0 W
C : 3	3,0 W
C : 1,5	1,5 W
C : 0,5	0,5 W

Sound pressure levels at 1W/1m w/P-3/10T same phase

SPL vs Freq

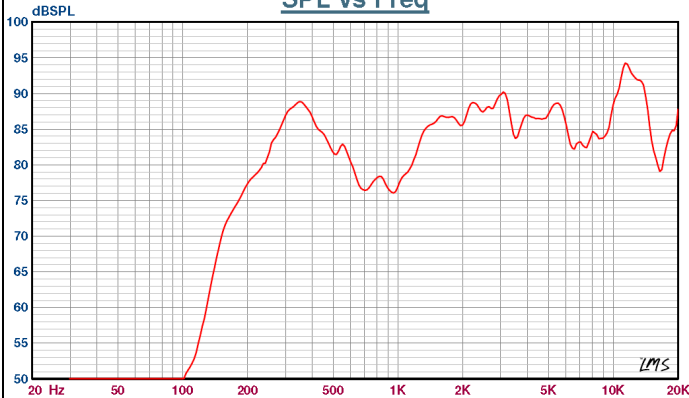

Specifications

Material / Color	ABS / RAL 7035
Mounting	Foot bracket
Termination	Ceramic screw terminals
Weight w/transformer	0,94 kg
IP-rating	44
Max. / min. amb. temp	90°C / -40°C
Rated power	6W
SPL 1W/1m	87 dB
SPL rated power	94 dB
Effective freq. range	150 – 20000 Hz
Dispersion (-6dB) 1kHz / 4kHz	360° / 2x70°(bidirectional)
Directivity factor, Q1kHz/4kHz	1 / 5,1
Options	Impedances, colors, labels

### Installation, Operation and Maintenance Procedures

- Fasten the loudspeaker to the wall by two screws.
- To open the loudspeaker, turn the front gently counterclockwise and pull.
- Lead cable through cable gland, connect to fused ceramic terminal and select required tapping into the transformer.
- If 70V, replace red cable with the green cable in the terminal.
- Close the loudspeaker turning the front gently clockwise until it stops.
- For optimum performance, always use the correct voltage / power and operate within the frequency limits as stated.
- Do not open loudspeaker when energized.
- This loudspeaker is supplied with two years warranty against defective workmanship.

DNH reserves the right to alter specifications without notice.

