



DNH

HP-8(T)

ISO 9001 CERTIFIED

Morrison's Public Address
Email: sales@morrison sav.com.au
Phone: 0407442822

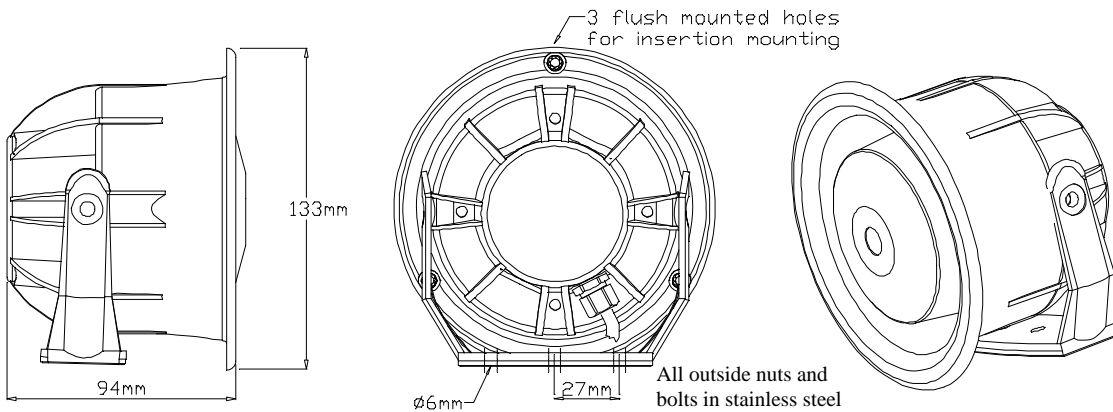

100V transformer Primary nominal tappings

Red	Yellow	8,0 W
Yellow	Green	4,0 W
Green	Blue	2,0 W
Red	Green	1,5 W
Yellow	Blue	0,7 W
Red	Blue	0,4 W

Sound pressure levels at 1W/1m MP-2,5

SPL vs Freq



Specifications

Material / Color	Polyamide / RAL 7035
Mounting	Bracket or insertion
Termination	0,5 m cable
Weight w/transformer	0,66 Kg
IP-rating	67
Max. / min. amb. temp	150°C / -50°C
Rated / max. power	8 W / 10 W
SPL 1W/1m	101 dB
SPL rated power	110 dB
Effective freq. range	300 – 20000 Hz
Dispersion (-6dB) 1kHz / 4kHz	
Directivity factor, Q	
Options	Impedance, colors, labels

Installation, Operation and Maintenance Procedures

- For insertion mounting punch three screws through knockout holes.
- Fasten bracket with 2-3 screws.
- The cable should be terminated in a suitable junction box.
- To change the position of the loudspeaker, please adjust the bracket (by loosening / tightening the screws) as required.
- For optimum performance, always use the correct voltage / power and operate within the frequency limits as stated.
- This loudspeaker is supplied with a 2 year warranty against defective workmanship.

DNH reserves the right to alter specifications without notice

