



DNH^{AS}

DSP-15 EExmN(T)

Morrison's Public Address (Australia)

Phone: 08 9493 1196

E-mail: sales@morrisonssav.com

www.morrisonssav.com

Fax: 08 9459 2869

ISO 9001 CERTIFIED

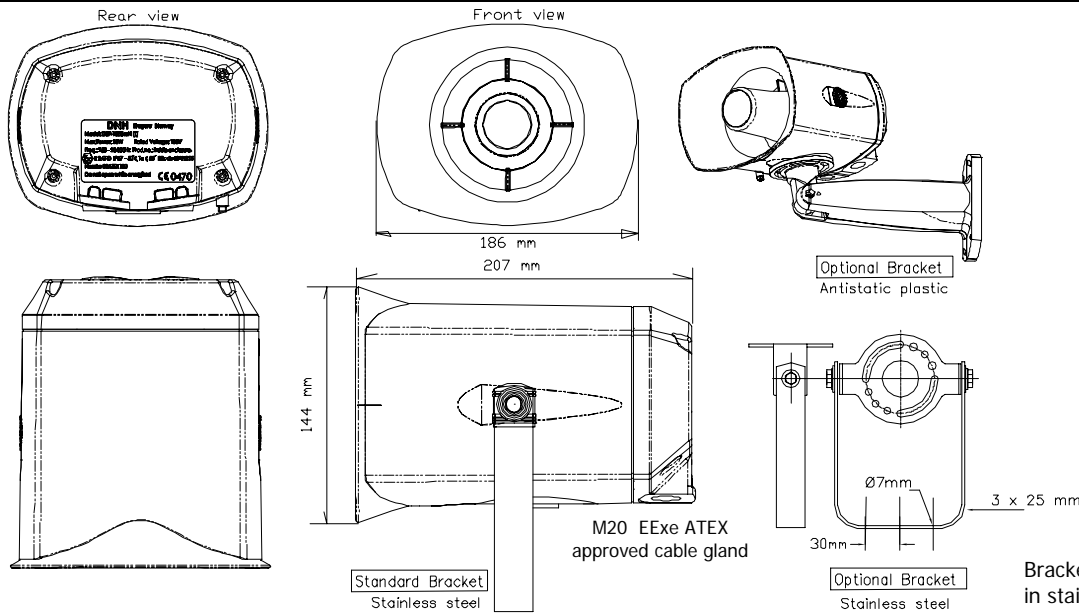

Transformer:
100 V line (options 70V, 50V)

HIGH primary tappings:
Yellow to black (4)
1 : 2 25,0 W
1 : 3 12,5 W

LOW primary tappings:
Yellow to white (4)
1 : 2 5,0 W
1 : 3 2,5 W

1 = Red, 2 = Yellow
3 = Blue

Loop in / Loop out

Bracket and all outside nuts and screws
in stainless steel.

Certified by/ Certification Code/ Number: NEMKO / Ex dema IIB + H2 T4 / IECEx NEM 05.0005

Certified by/ Certification code/ Number: NEMKO / Ex dema IIC T4 / IECEx NEM 05.0005



1W/1m Pink Noise 1/3 octave bands
(Curve shows DSP-15 EExeN IIB+H₂ version)

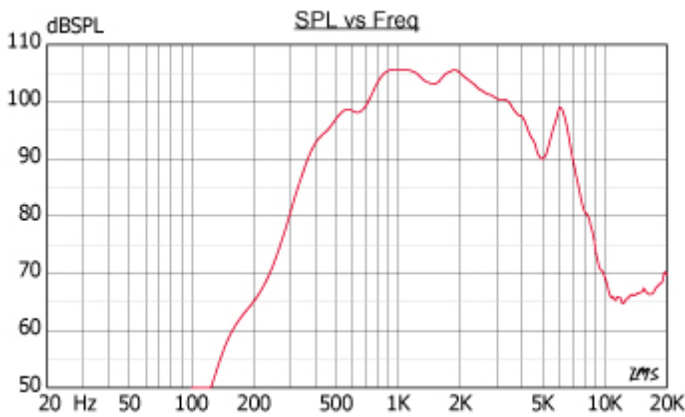

	IIB	IIC
Material / Color	Anti-static PA / Black	
Mounting	Bracket	
Termination	e-chamber, screw terminals	
Weight w/ transformer	2,2 kg	
IP-rating (UL equivalent)	67	
Max / min amb temp	55°C / -50°C	
Rated / max power	25 W / 25 W	
SPL 1W/1m.....	105 dB	102 dB
SPL rated power	117 dB	114 dB
Effective freq range.....	410 – 7000 Hz	500-6000
Dispersion (-6dB) 1kHz / 4kHz	200° / 50°	105° / 35°
Directivity factor, Q (1 kHz)	1,8	
Options	Impedances, colors, labels	

Installation, Operation and Maintenance Procedures

- When mounting the loudspeaker please ensure that it is re-assembled in the same manner in which it was received. Fasten bracket with 1-3 screws.
- To change the position of the loudspeaker, please adjust the standard U- bracket (by loosening / tightening the screws) as required.
- DSP-15 EExmN/T IECEx 25W can be supplied with 3 different bracket systems, according to customer requirements.
- For optimum performance, always use the correct voltage / power and operate within the frequency limits as stated.
- Use only certified/specified cable glands and blanking plugs.
- Do not open loudspeaker when energized.
- Fasten lid with a torque of 2 - 3 Nm.
- This loudspeaker is supplied with a 2 year warranty against defective workmanship.



DNH reserves the right to alter specifications without notice.

Rev. 23.10.2006