

PROHDCART product information sheet

Product Specifications

Fits most: 37" - 55" flat panels

Supports up to: 125 lbs (56.7 kg)*

Shelf capacity: 40 lbs (18.1 kg)

Tilt: -5° to +15°

Universal and VESA compliant: 100x200 to 500x900

UL Listed: Yes

Warranty: 5 years

Color: Black

*Total capacity including panel and components not to exceed 125 lbs (56.7 kg)

Product Benefits

- Telescoping post with locking pin allows for height adjustment from 51" to 72" in 1-inch increments (measured from floor to center of mount head)
- Includes universal adapter for greater panel compatibility
- Lift n' Lock™ for quick installation
- Displays can be mounted in portrait or landscape orientation
- Adjustable and lockable shelf comes with component strap and can be repositioned in 1" increments
- Shelf can be positioned in front or back to hide components when needed
- Integrated in-post cable management
- AC cord wrap for hassle-free transport
- Nesting base for easy storing of multiple carts
- Caster base with four locking, non-scuffing 4-inch wheels provide safe and easy movement over any surface
- Rubberized bumpers won't scuff walls or doors
- Quick assembly
- Additional shelves available as an accessory
- Complete Grade 5 hardware kit



Carts and Stands



PROHDCART



PROIQCART



FSUA



FS



Caster base with locking wheels



Telescoping height adjustment



Portrait or landscape orientation



AC cord wrap for hassle-free transport

Dedicated to being a one-stop-shop for professional products, OmniMount remains on the cutting edge of product innovation. That's why we're the natural choice for any professional, industrial or commercial application. Understanding the needs of the market, OmniMount manufactures a full line of carts and stands that are second to none. The PROHDCART is a heavy duty flat panel cart offering convenient mobility and functionality.



PROHDCART technical data sheet



Dedicated to being a one-stop-shop for professional products, OmniMount remains on the cutting edge of product innovation. That's why we're the natural choice for any professional, industrial or commercial application. Understanding the needs of the market, OmniMount manufacturers a full line of carts and stands that are second to none. The PROHDCART is a heavy duty flat panel cart offering convenient mobility and functionality.

Product Specifications

Fits most: 37" - 55" flat panels

Supports up to: 125 lbs (56.7 kg)*

Shelf capacity: 40 lbs (18.1 kg)

Tilt: -5° to +15°

Universal and VESA compliant: 100x200 to 500x900

UL Listed: Yes

Warranty: 5 years

Color: Black

*Total capacity including panel and components not to exceed 125 lbs (56.7 kg)

Product Benefits

- Telescoping post with locking pin allows for height adjustment from 51" to 72" in 1-inch increments (measured from floor to center of mount head)
- Includes universal adapter for greater panel compatibility
- Lift n' Lock™ for quick installation
- Displays can be mounted in portrait or landscape orientation
- Adjustable and lockable shelf comes with component strap and can be repositioned in 1" increments
- Shelf can be positioned in front or back to hide components when needed
- Integrated in-post cable management
- AC cord wrap for hassle-free transport
- Nesting base for easy storing of multiple carts
- Caster base with four locking, non-scuffing 4-inch wheels provide safe and easy movement over any surface
- Rubberized bumpers won't scuff walls or doors
- Quick assembly
- Additional shelves available as an accessory
- Complete Grade 5 hardware kit



	Stock Code	Packaging UPC	MC UPC
Americas	1004711-1	728901025624	728901719073
International	NA	NA	NA

	Dimensions WxDxH inches (cm)	Wt lbs (kg)	Qty
Box	31.3 x 53,7 x 12 (795x1365x305)	95.9 (43.5)	NA
MC	NA	NA	NA

Box Contents	Qty
Right leg	1
Left leg	1
Base support	1
Base cover	1
Vertical support	1
Handle	1
VESA plate	1

Box Contents	Qty
Universal adapter	1
Universal adapter cover	1
Shelf	1
Caster	4
Security strap	1
Complete hardware kit	1
Instruction manual	1

PROHDCART line drawing

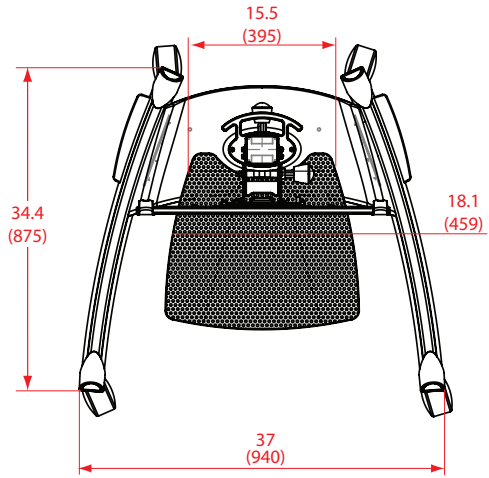

Mount head is VESA 100x200,
200x200,300x200 compliant

