

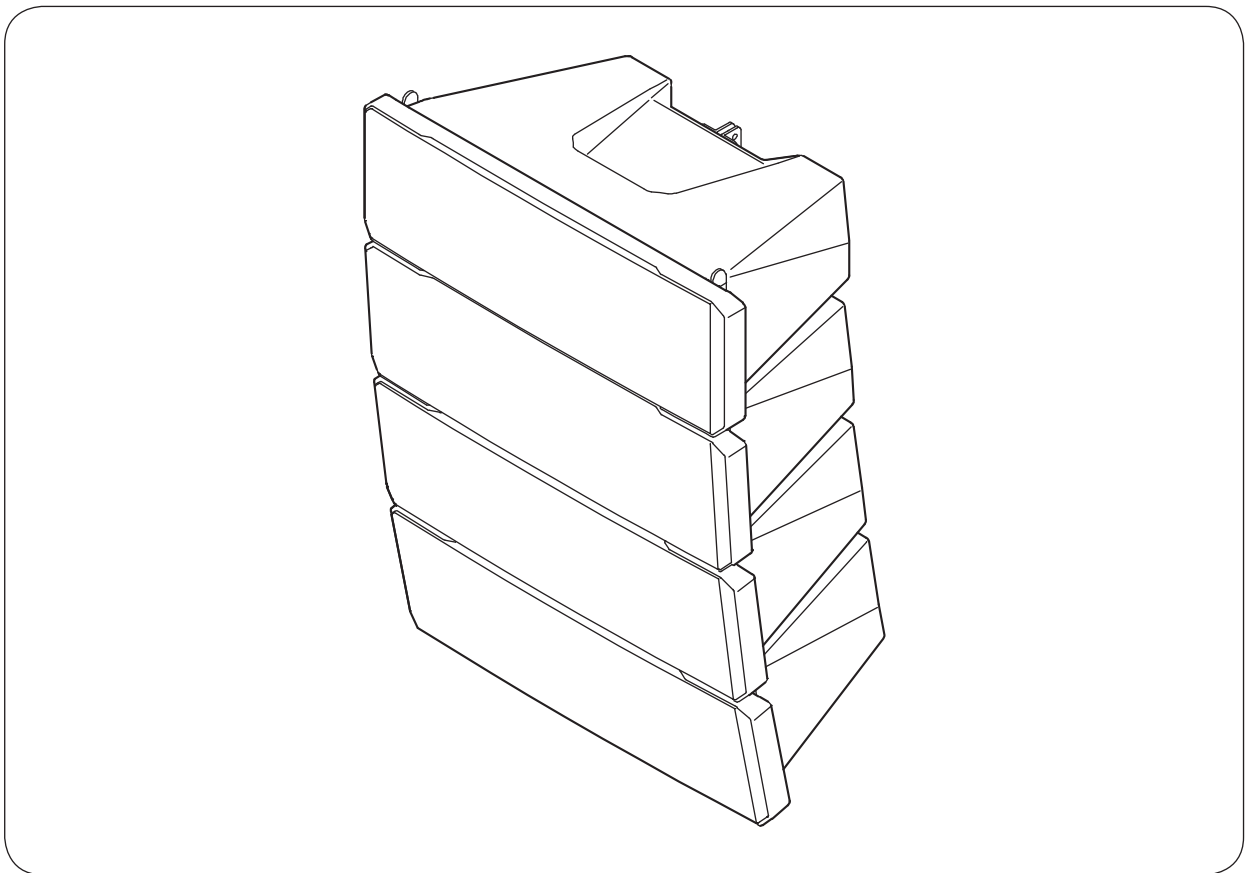

OPERATING INSTRUCTIONS

SPEAKER SYSTEMS

HX-7B
HX-7W
HX-7B-WP
HX-7W-WP



 **WARNING**

When using the speaker as shipped from the factory, be sure to retighten the bolts holding the rear-mounted brackets with a designated tightening torque. (See p. 8, "When Using the Directivity Angle at 0° Mode.")

Failure to retighten the bolts may cause the speaker to fall, resulting in personal injury.

Thank you for purchasing TOA's Speaker Systems.

Please carefully follow the instructions in this manual to ensure long, trouble-free use of your equipment.

TOA Corporation

TABLE OF CONTENTS

| | |
|--|----|
| 1. SAFETY PRECAUTIONS | 3 |
| 2. GENERAL DESCRIPTION | 4 |
| 3. FEATURES | 4 |
| 4. NOTES ON OUTDOOR INSTALLATIONS (HX-7B-WP and HX-7W-WP only) | 5 |
| 5. DIMENSIONAL DIAGRAM | 5 |
| 6. INPUT SECTION | 6 |
| 6.1. HX-7B and HX-7W | 6 |
| 6.2. HX-7B-WP and HX-7W-WP | 7 |
| 7. SETTING THE SPEAKER'S DIRECTIVITY ANGLE MODE ... | 7 |
| 7.1. When Using the Directivity Angle at 0° Modes | 8 |
| 7.2. Changing the Directivity Angle to Between 15° and 45° Modes | 8 |
| 7.3. Changing the Directivity Angle to 60° Mode | 9 |
| 8. USING THE SUPPLIED SUSPENSION BRACKETS (HX-7B and HX-7W only) | 9 |
| 9. OPTIONAL MOUNTING BRACKETS | 12 |
| 9.1. Types of Mounting Brackets | 12 |
| 9.2. Installation Examples | 13 |
| 10. SAFETY WIRE INSTALLATION | 14 |
| 11. EQUALIZATION USING A DIGITAL SIGNAL PROCESSOR | 15 |
| 12. COMBINATION WITH THE MATCHING TRANSFORMER | 17 |
| 13. SPECIFICATIONS | 17 |

1. SAFETY PRECAUTIONS

- Before installation or use, be sure to carefully read all the instructions in this section for correct and safe operation.
- Be sure to follow all the precautionary instructions in this section, which contain important warnings and/or cautions regarding safety.
- After reading, keep this manual handy for future reference.

Safety Symbol and Message Conventions

Safety symbols and messages described below are used in this manual to prevent bodily injury and property damage which could result from mishandling. Before operating your product, read this manual first and understand the safety symbols and messages so you are thoroughly aware of the potential safety hazards.



WARNING

Indicates a potentially hazardous situation which, if mishandled, could result in death or serious personal injury.



CAUTION

Indicates a potentially hazardous situation which, if mishandled, could result in moderate or minor personal injury, and/or property damage.



WARNING

When Installing the Unit

- Avoid installing or mounting the speaker in unstable locations, such as on a rickety table or a slanted surface.
Doing so may result in the speaker falling down and causing personal injury and/or property damage.
- Refer all installation work to the dealer from whom the speaker was purchased. Installation for flying requires extensive technical knowledge and experience. The speaker may fall off if incorrectly installed, resulting in possible personal injury.
- Flying Precautions
Be sure to follow the instructions below. Otherwise, the suspension wires or belts may be off or snap and the speaker may fall off, causing personal injury.
 - Check to confirm that the suspension wires and belts are strong enough to withstand the speaker load.
 - The connectors of the suspension wires and belts must be securely linked with those of the speaker.
 - All parts and components (such as enclosures, metal pieces, and screws) must be free from any deformation, crack, and corrosion.
 - Be sure to use screws supplied with the optional flying hardware when installing the speaker using such hardware.
- Install the speaker only in a location that can structurally support the weight of the speaker and the mounting bracket. Doing otherwise may result in the speaker falling down and causing personal injury and/or property damage.
- (HX-7B-WP and HX-7W-WP only)
When installing the speaker under the eaves in the snowy area, take appropriate measures to prevent snow from lying on the speaker. If snow lies on the speaker, it may fall, causing personal injuries.
- Owing to the speaker's size and weight, be sure that at least two persons are available to install the speaker. Failure to do so could result in personal injury.
- (HX-7B and HX-7W only)
Since the speaker is designed for indoor use, do not install it outdoors.
If installed outdoors, the aging of parts causes the speaker to fall off, resulting in personal injury. Also, when it gets wet with rain, there is a danger of electric shock.
- Do not use other methods than specified to mount the speaker. Extreme force is applied to the speaker and it could fall off, possibly resulting in personal injuries.
- Attach the safety wire to the speaker. If not attached, the speaker could fall off, resulting in personal injury.
- Use nuts and bolts that are appropriate for the ceiling's or wall's structure and composition. Failure to do so may cause the speaker to fall, resulting in material damage and possible personal injury.
- Tighten each nut and bolt securely. Ensure that the bracket has no loose joints after installation to prevent accidents that could result in personal injury.
- Use the specified mounting bracket and matching transformer in combination.
Doing otherwise may cause the speaker or

component to fall off, resulting in personal injury.

- Do not mount the speaker in locations exposed to constant vibration. The mounting bracket can be damaged by excessive vibration, potentially causing the speaker to fall, which could result in personal injury.
- Do not use anti-rust lubricant. If it contacts resin or rubber parts, they could deteriorate and cause the speaker to fall, possibly resulting in personal injury.
- Avoid installing the speaker in locations close to the seashore or in indoor swimming facilities that are not well ventilated. In such locations, the bracket may be vulnerable to corrosion, eventually allowing the speaker to fall resulting in personal injury.

CAUTION

When Installing the Unit

- Avoid touching the speaker's sharp metal edge to prevent injury.

- To avoid electric shocks, be sure to switch off the amplifier's power when connecting speakers.

When the Unit is in Use

- Do not place heavy objects on the speaker as this may cause it to fall or break which may result in personal injury and/or property damage. In addition, the object itself may fall off and cause injury and/or damage.
- Do not operate the speaker for an extended period of time with the sound distorting. Doing so may cause the connected speakers to heat, resulting in a fire.
- Do not stand or sit on, nor hang down from the speaker as this may cause it to fall down or drop, resulting in personal injury and/or property damage.
- Have the speaker checked periodically by the shop from where it was purchased. Failure to do so may result in corrosion or damage to the speaker or its mounting bracket that could cause the speaker to fall, possibly causing personal injury.

2. GENERAL DESCRIPTION

The HX-7 Series is a 2-way compact speaker system that permits both constant directivity control over a wide frequency range and changes in vertical directivity angle.

The HX-7 Series Speaker System employs its unique Wavefront control technology, providing clearly audible speech amplification in locations that suffer from long reverberation times or high background noise levels.

The lineup consists of the HX-7B and HX-7W Speaker Systems for indoor applications, and the HX-7B-WP and HX-7W-WP Speaker Systems for outdoor installations under eaves or other areas protected from direct exposure to the elements. An optional selection of mounting brackets allows these speaker systems to meet a wide range of acoustic applications, including both permanent and temporary installations.

3. FEATURES

- Each speaker module is equipped with two 13 cm (5.5") woofers and one compression driver. Four speaker modules are combined into one high-quality, high-powered speaker system.
- TOA's unique Wavefront control technology offers exceptional speech clarity and long-distance voice transmission capabilities.
- The directivity angle mode of the four speaker modules in each speaker system can be changed to between 0° and 45°. The directivity angle mode can also be increased to a maximum angle of 60° by using optionally available brackets.
- Ideal for both permanent and temporary installations, including both vertical and horizontal positioning.
- These speaker systems can be used in combination with the FB-150 Series Subwoofer System.
- Can be suspended by wires, chains or shackles with no need to use optional brackets.
- Optional mounting brackets allow use in a wide variety of applications, including suspension, ceiling mounting, wall mounting, and speaker stand mounting. Mounting procedures are described in the instruction manuals enclosed with the mounting bracket or stand adapter.
- Two speaker systems can be joined together using optional joint brackets.
- Speaker systems can also be connected to an amplifier's high-impedance output with the use of an optional matching transformer.

4. NOTES ON OUTDOOR INSTALLATIONS (HX-7B-WP and HX-7W-WP only)

Only the HX-7B-WP and HX-7W-WP are suitable for installation under the eaves. For installation under the eaves, observe the following precautions.

- All speaker modules must point downward from the horizontal. Failure to do so could adversely affect their intended splash-proof and weather-resistant capability, leading to malfunction.
- Both the HX-7B-WP and the HX-7W-WP employ a splash-proof construction that allows them to be installed under the eaves, but they should only be installed in locations where the ambient temperature is within the range of $-15\text{ }^{\circ}\text{C}$ to $+50\text{ }^{\circ}\text{C}$ ($5\text{ }^{\circ}\text{F}$ to $122\text{ }^{\circ}\text{F}$). Exceeding the temperature range will cause the speaker to fail.
- Connect speaker cables using the supplied terminal covers. (See p. 7.)

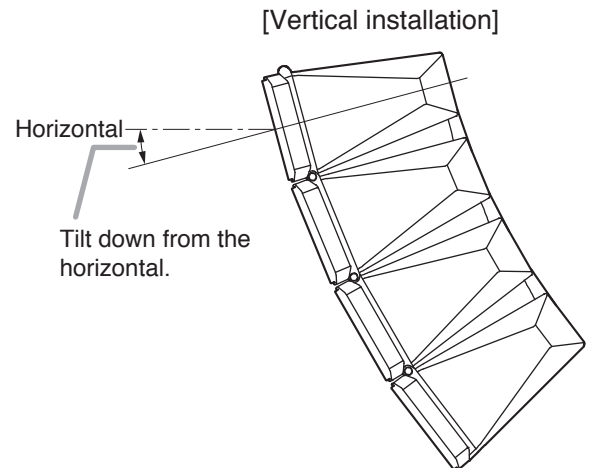

5. DIMENSIONAL DIAGRAM

Unit: mm

[Top]

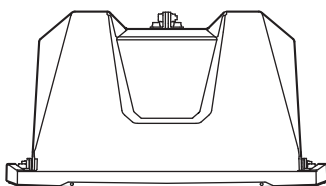

• HX-7B/7W Input section

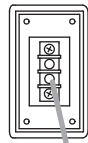

Screw terminals

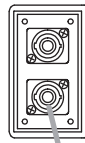

Speakon
NL4MP connector

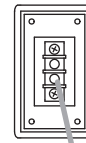

Screw terminals



Attach the supplied
terminal cover.
(See p. 7.)

[Front]

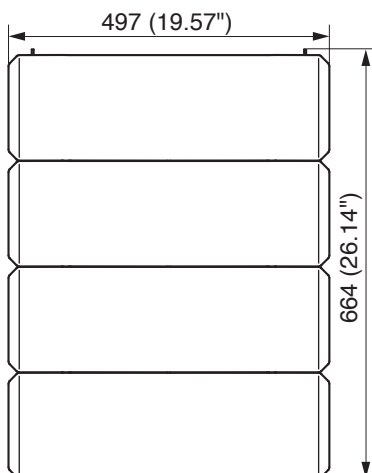

[Side]

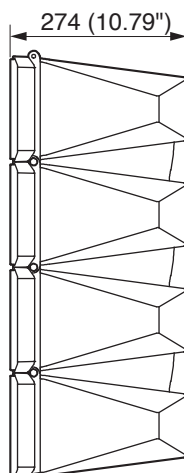

[Rear (HX-7B/7W)]

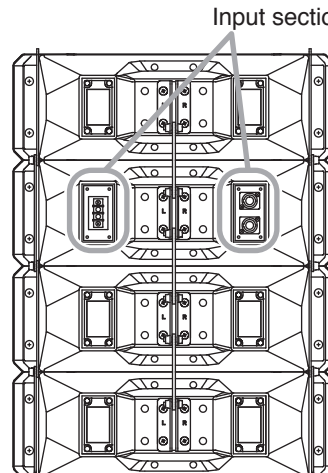

Input section

[Rear
(HX-7B-WP/7W-WP)]

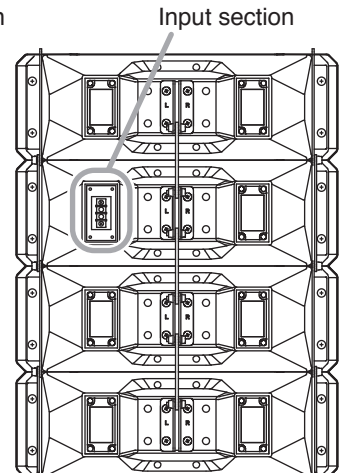

Input section

Note

In the above illustrations, the directivity angle is set to 0° mode (default setting).

6. INPUT SECTION

6.1. HX-7B and HX-7W

- The 2 Speakon connectors are internally connected in parallel to the screw terminals; you can use either one.
- The right table shows the pin arrangement of the Speakon NL4MP connector.

| Pin No. | HX-7B, HX-7W |
|---------|--------------|
| 1 + | Speaker + |
| 1 - | Speaker - |
| 2 + | — |
| 2 - | — |

- The usable connector (on the cable end) for the Speakon NL4MP is Speakon NL4FC or NL4FX.
- Wiring diagram of the input connectors is shown at right.

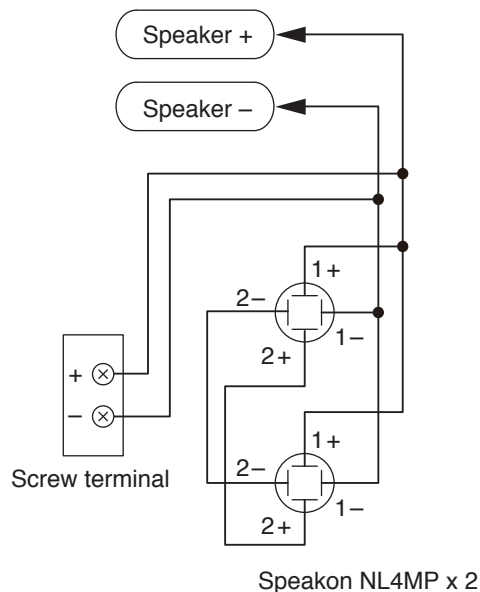

- Two speaker systems can be operated in parallel by connecting them in a cascade configuration as shown at right.

Note

Be sure to connect the speaker system to the power amplifier's output terminal of 4 Ω or less. Connecting it to an output terminal of over 4 Ω may cause amplifier failure.

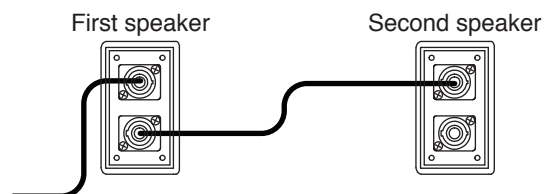

6.2. HX-7B-WP and HX-7W-WP

Connect the speaker cable to the screw terminal using the supplied terminal cover and rubber gasket.

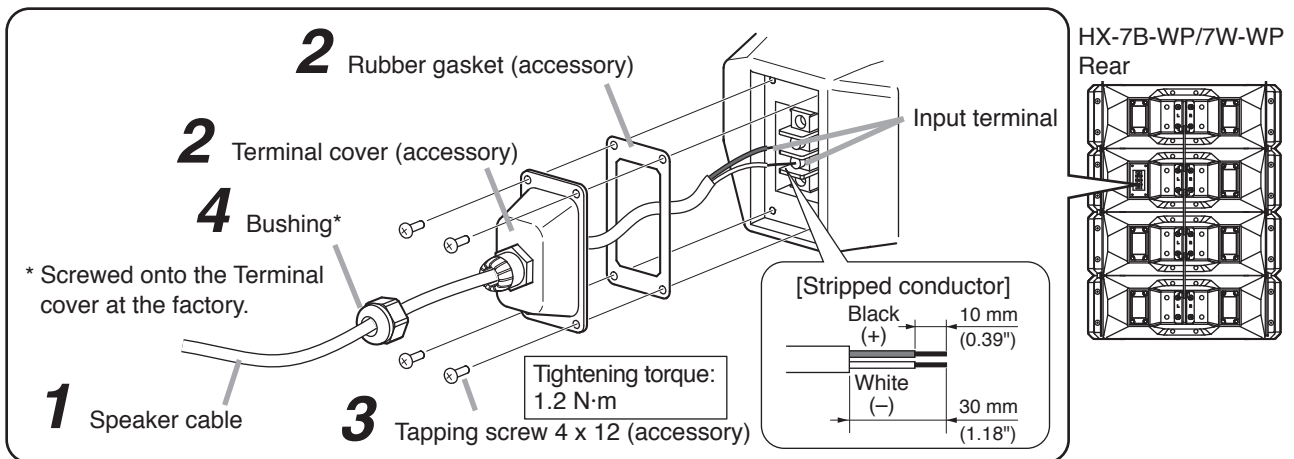

Notes

- Separately prepare the speaker cable with a diameter of 6 – 10 mm (0.24 – 0.39"), which will fit the cable bushing.
- To ensure waterproof capabilities, firmly mount the terminal cover to the speaker and tighten the bushing on the cover. Also be sure to insert the rubber gasket between the terminal cover and the speaker.

Step 1. Feed the speaker cable through the bushing, terminal cover, and rubber gasket, then connect the cable to the input terminal.

Step 2. Attach the rubber gasket and terminal cover to the speaker.
Attach the cover while pulling the cable so that it is not entangled inside the terminal cover.

Step 3. Hold the terminal cover tightly to the speaker using the supplied screws.

Step 4. Tighten the bushing.

Note

After tightening the bushing by hand, use a wrench to further tighten it another 90° (1/4-turn) or so.
Note that parts can be damaged by over-tightening.

7. SETTING THE SPEAKER'S DIRECTIVITY ANGLE MODE

The speaker's directivity angle mode is factory-preset to 0° mode, but this mode can be changed to 15° mode, 30° mode, 45° mode, or 60° mode. (See p. 8 and 9.)

For 60° mode setting, an optional bracket is required. (See p. 9.)

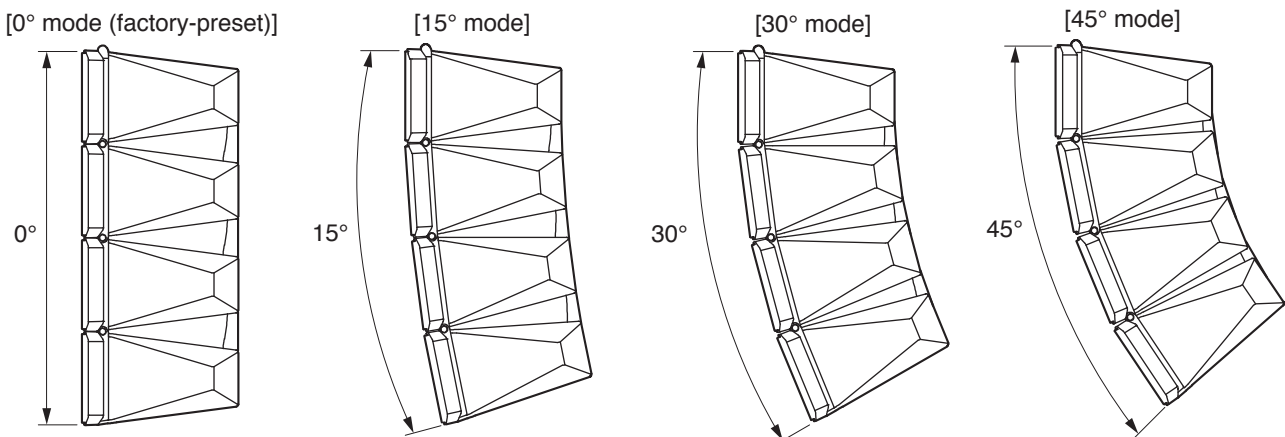



WARNING

Tighten the bolts securely, as instructed below. Failure to follow instructions precisely could result in a falling speaker and potential personal injury.

- Ensure that all bolts are securely inserted as far as their threads go, then securely fasten each bolt with a nut.
- Tighten all the bolts with the designated tightening torque. For tightening, use a Phillips screwdriver, or open- or box-end wrench.

7.1. When Using the Directivity Angle at 0° Mode

Leave the positions of the bolts holding the rear angle bars unchanged as their default. However, be sure to retighten all the bolts with the designated tightening torque to secure the rear angle bars.

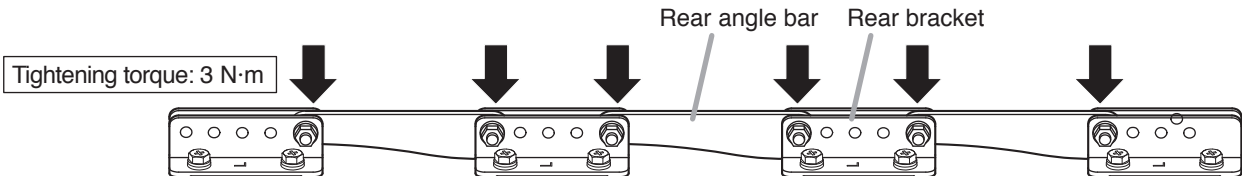

7.2. Changing the Directivity Angle to Between 15° and 45° Modes

Before changing angle modes, lay out a protective sheet, corrugated cardboard or other soft material on a flat surface, and perform all work on the speaker with its front baffle facing downward. As the speaker assembly is quite heavy, it is recommended that at least two persons be involved in the modification work. As an example, the HX-7 Series speakers shown in the figure below are arranged in a direction that exposes the speaker's left-side protection covers.

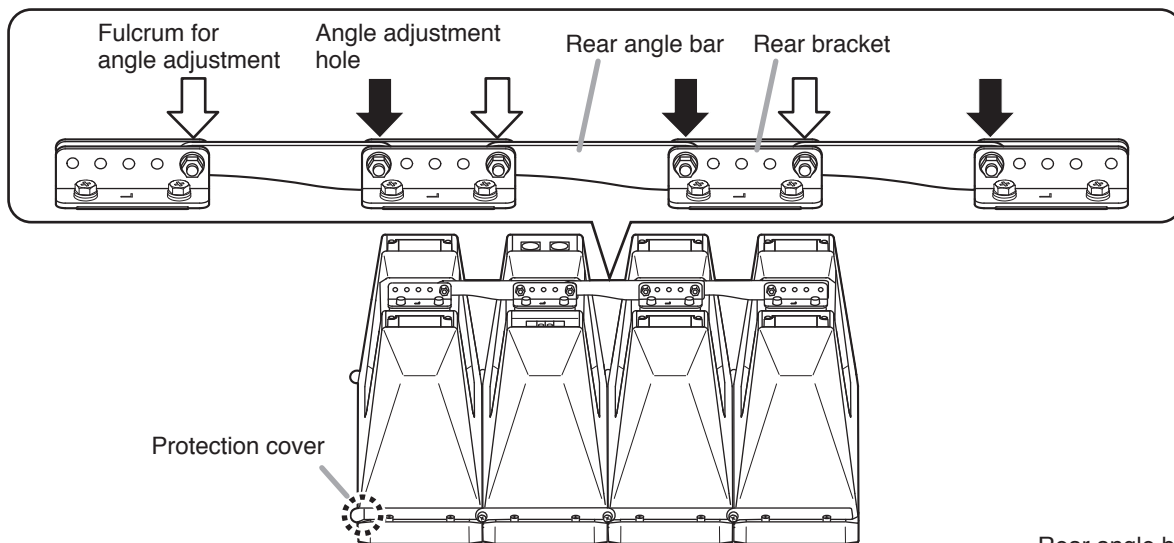

Step 1. Remove one nut and bolt for each rear angle bar (as indicated by the black arrow in the figure at right).

Notes

- The nut and bolt indicated by the white arrow become the fulcrum for angle adjustment. Since the rear angle bar can be moved at the fulcrum with the nut and bolt assembled there, do not loosen or detach.
- Do not change the fulcrum position. If changed, the directivity angle mode will not assume its specified value.

Step 2. Align the hole in the rear angle bar (disconnected in Step 1 above) with the desired directivity angle mode position, then reinsert the bolt in the bracket and bar, and securely tighten the bolt with a nut.

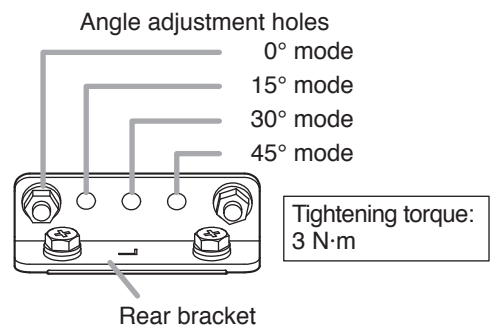
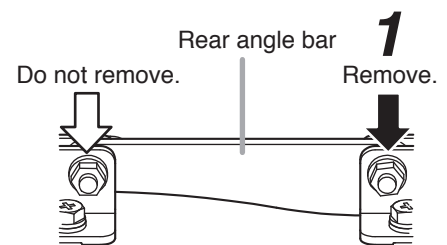

7.3. Changing the Directivity Angle to 60° Mode

Optional brackets are required to change to 60° mode.
 Select the brackets that correspond to the speakers to be used.

| Speaker system | Angle adjustment bracket (optional product) |
|----------------|---|
| HX-7B | HY-60DB |
| HX-7W | HY-60DW |
| HX-7B-WP | HY-60DB-WP |
| HX-7W-WP | HY-60DW-WP |

For the mounting method of the angle adjustment bracket, refer to the bracket's instruction manual.

8. USING THE SUPPLIED SUSPENSION BRACKETS (HX-7B and HY-7W only)

The HX-7B and HX-7W speaker systems can be suspended in either vertical or horizontal orientation using the supplied suspension brackets.

Before mounting the suspension brackets, lay out a protective sheet, corrugated cardboard or other soft material on a flat surface, and perform all work on the speaker with its front baffle facing downward.



WARNING

- Tighten the bolts securely, as instructed below.
 Failure to follow instructions precisely could result in a falling speaker and potential personal injury.
- Ensure that all bolts are securely inserted as far as their threads go, then securely fasten each bolt with a nut.
- Tighten all the bolts with the designated tightening torque.
 For tightening, use a Phillips screwdriver, or open- or box-end wrench.
- Owing to the speaker's size and weight, be sure that at least two persons are available for flying installation of the speaker. Failure to do so could result in personal injury.

Step 1. Detach the side angle bolts indicated by the arrows in the figure below.
 The bolts to be detached defer depending on the speaker's vertical or horizontal suspension orientation.

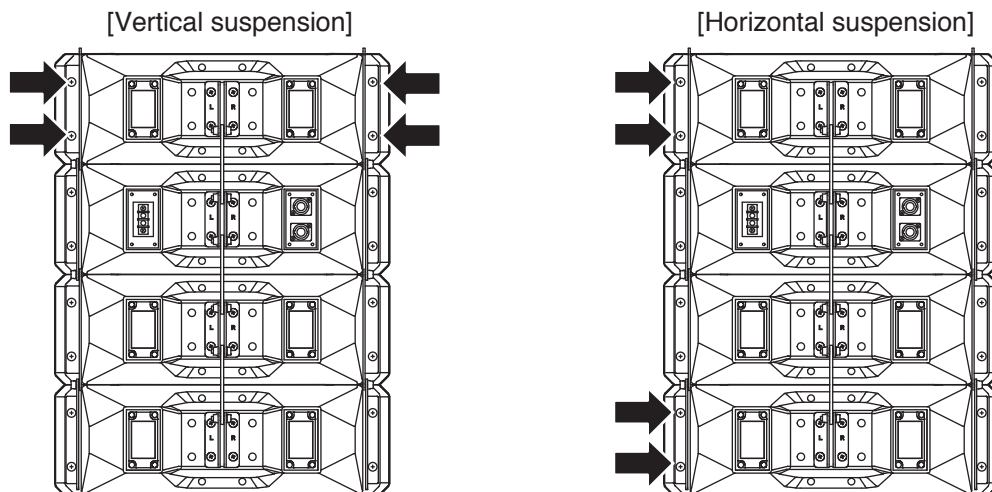

Note
 The bolts on the opposite side of the speaker system can also be detached for suspension bracket attachment.

Step 2. Using the supplied bolts, tighten the suspension brackets together with the side angle plates. Attach the brackets with the suspension holes facing outward.

Note

Do not use the bolts detached in Step 1.

[Vertical suspension]

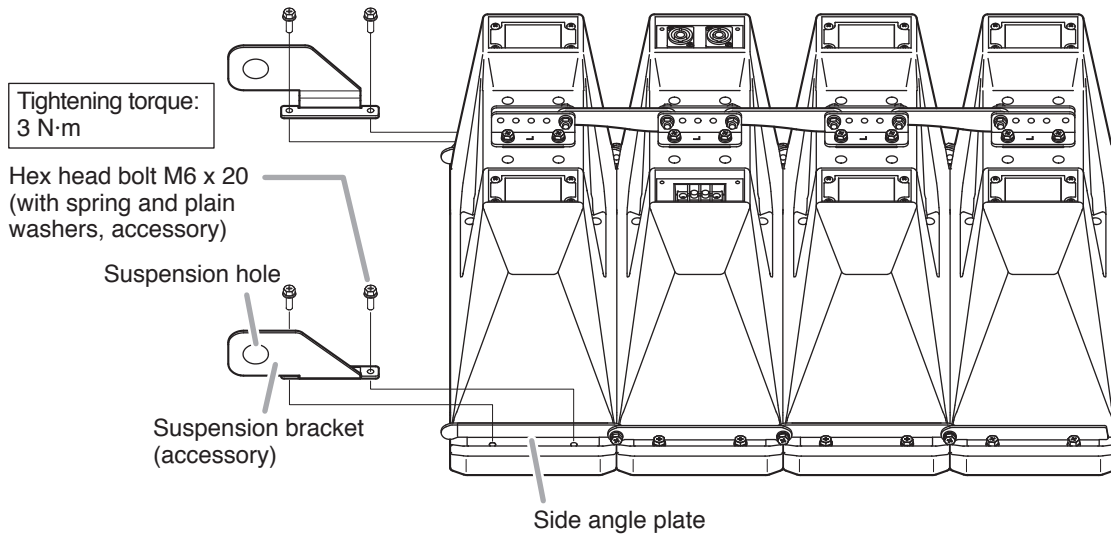

[Horizontal suspension]

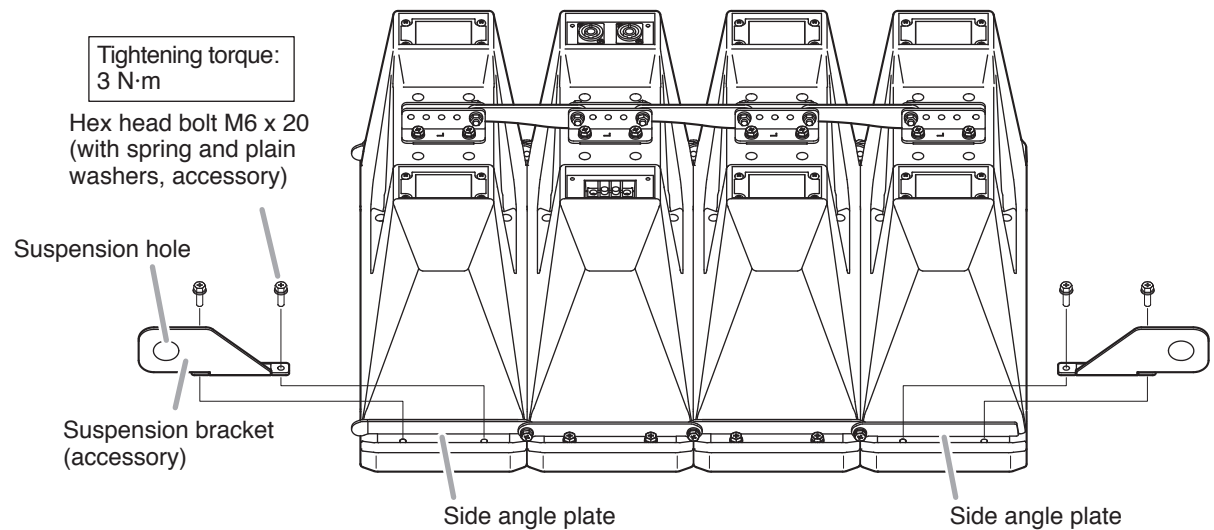

Note

Suspension bracket arrangement differs when two joined speaker systems are suspended horizontally. For details, refer to the installation manual supplied with the optional HY-CN7 Series Speaker Connection Bracket.

Step 3. Suspend the speaker system at 3 points using appropriate commercially obtained wires, chains, or anchor shackles.

! WARNING

Observe the following instructions when suspending the speakers.

Doing otherwise may cause the speaker system to fall, potentially resulting in personal injury.

- Use wires, chains, or anchor shackles that are strong enough to withstand the total weight of the suspended components.
- Pass anchor shackles, etc. through the holes in the suspension brackets (2 places) and the rear bracket (1 place).
- When suspending joined speaker systems horizontally, hang each speaker at 3 points shown in the figure below.

[Vertical suspension]

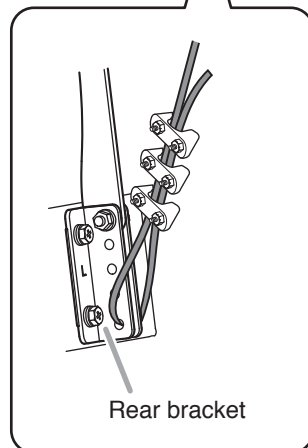
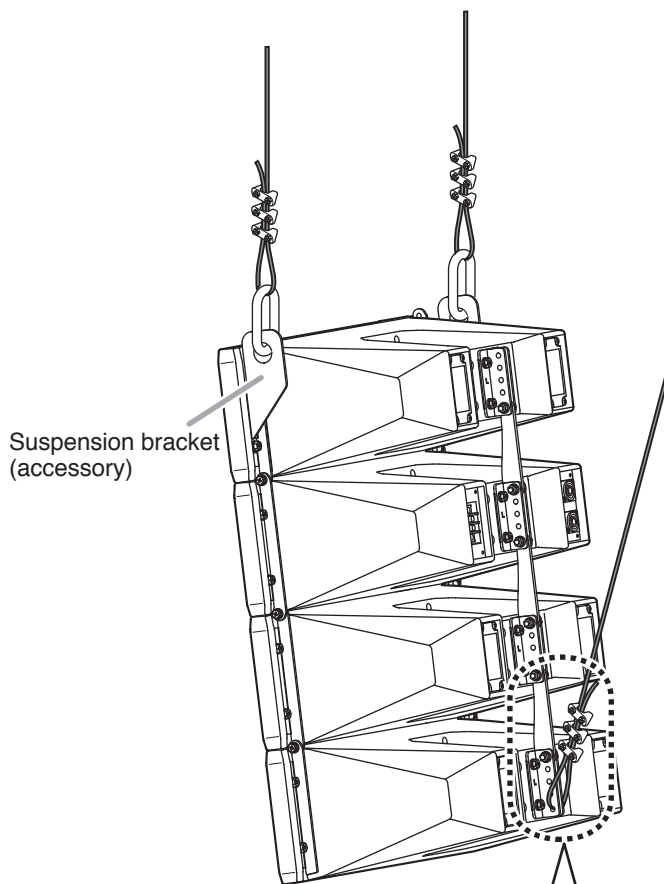

[Horizontal suspension]

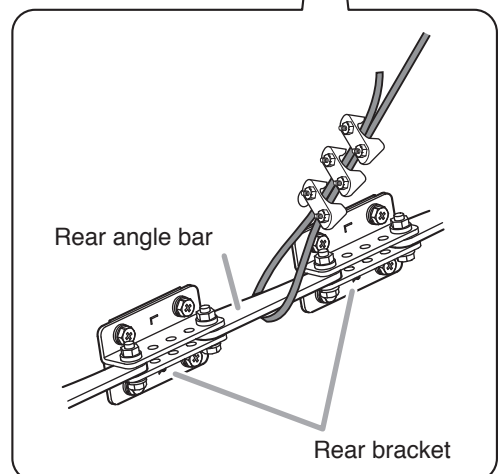
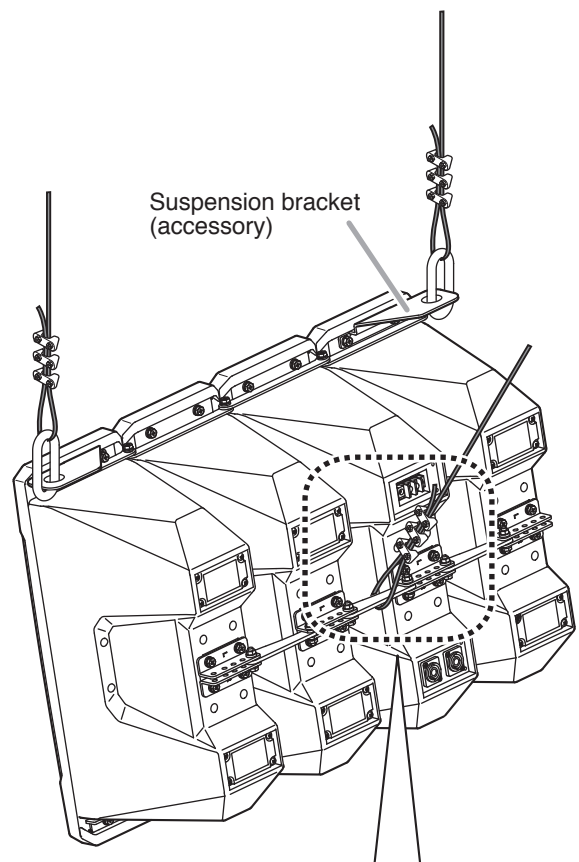

9. OPTIONAL MOUNTING BRACKETS

9.1. Types of Mounting Brackets

The following mounting brackets are optional. For usage, refer to the instruction manual enclosed with each set of brackets.

[Table of Mounting Brackets for Speaker Systems]

| Speaker system | | Mounting bracket | | | | Remarks |
|--------------------------------------|------------|------------------|-------|----------|----------|---|
| | | HX-7B | HX-7W | HX-7B-WP | HX-7W-WP | |
| Speaker connection bracket | HY-CN7B | ✓ | | | | For joining two speaker systems together, permitting directivity to be controlled for lower frequencies. |
| | HY-CN7W | | ✓ | | | |
| | HY-CN7B-WP | | | ✓ | | |
| | HY-CN7W-WP | | | | ✓ | |
| Angle adjustment bracket | HY-60DB | ✓ | | | | For changing speaker system directivity angle mode to 60°. |
| | HY-60DW | | ✓ | | | |
| | HY-60DB-WP | | | ✓ | | |
| | HY-60DW-WP | | | | ✓ | |
| Speaker rigging frame *1 | HY-PF7B | ✓ | | | | For high ceiling speaker suspension. |
| | HY-PF7W | | ✓ | | | |
| Speaker rigging bracket *1, *2 | HY-VM7B | ✓ | | | | For direct mounting to indoor ceilings or structural beams. Flying installations also possible by attaching eyebolts. |
| | HY-VM7W | | ✓ | | | |
| Speaker wall mounting bracket *1, *2 | HY-WM7B | ✓ | | | | For direct mounting to indoor walls. Speaker systems can be tilted downward or rotated horizontally while mounted to the wall. Designed for use with HY-VM7B or HY-VM7W brackets. |
| | HY-WM7W | | ✓ | | | |
| Speaker stand adapter *1, *2 | HY-ST7 | ✓ | ✓ | | | For indoor installations on speaker stands. Note Prepare speaker stands and speaker stand adapters separately. |
| Speaker rigging bracket *1, *2 | HY-TM7B-WP | | | ✓ | | For direct mounting to building structures, such as ceilings and under-eave beams. |
| | HY-TM7W-WP | | | | ✓ | |
| Speaker wall mounting bracket *1, *2 | HY-MS7B-WP | | | ✓ | | For mounting to under-eave walls. |
| | HY-MS7W-WP | | | | ✓ | |
| Matching transformer adapter | HY-MT7 | ✓ | ✓ | ✓ *3 | ✓ *3 | For mounting optional MT-200 Matching Transformer. |

*1 HX-7 Series speakers cannot be mounted horizontally.

*2 Cannot mount two joined HX-7 Series speaker systems.

*3 To ensure waterproof capability, the MT-200 Matching Transformer can only be attached to horizontally mounted HX-7 Series speaker systems.

9.2. Installation Examples

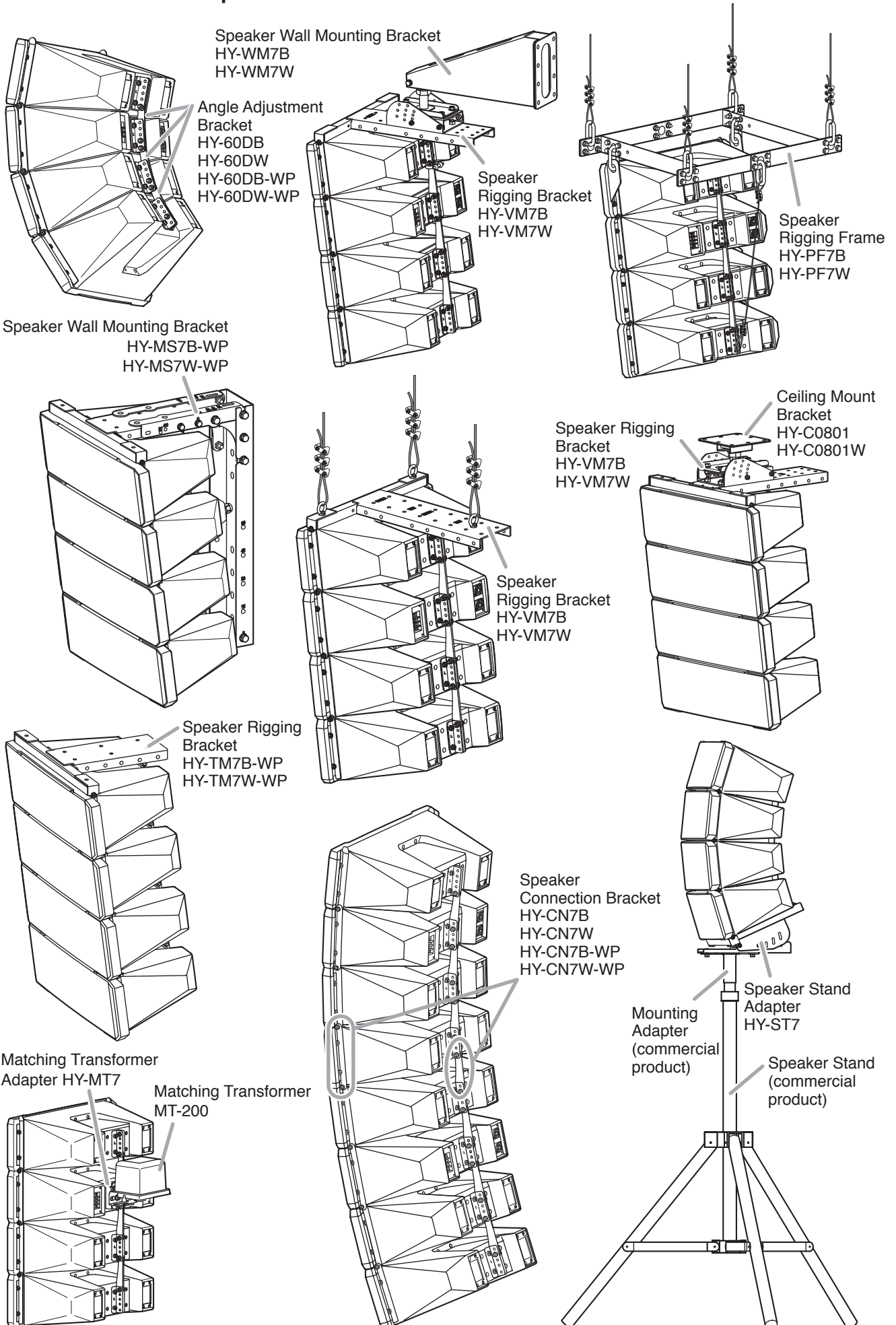

10. SAFETY WIRE INSTALLATION

Be sure to always use safety wire when installing speaker systems.

Note

Safety wires, shackles, and other suspension parts are not supplied with the speaker systems, and must be prepared separately.

WARNING

Be sure to follow all instructions regarding safety wire installation. If not correctly followed, speakers could fall, potentially resulting in personal injury.

- Use safety wire that is strong enough to suspend the full weight of the components to be installed.
- Attach a shackle to the rear angle bar and install suspension bolts to the wall or ceiling as shown in the figure at right.
- Only install speaker systems in locations capable of structurally supporting the weight of the speakers and their mounting brackets.

[Wall Mounting Example]

In this example, the optional HY-VM7B and HY-WM7B brackets are used.

Weight: 39.8 kg (87.74 lb)

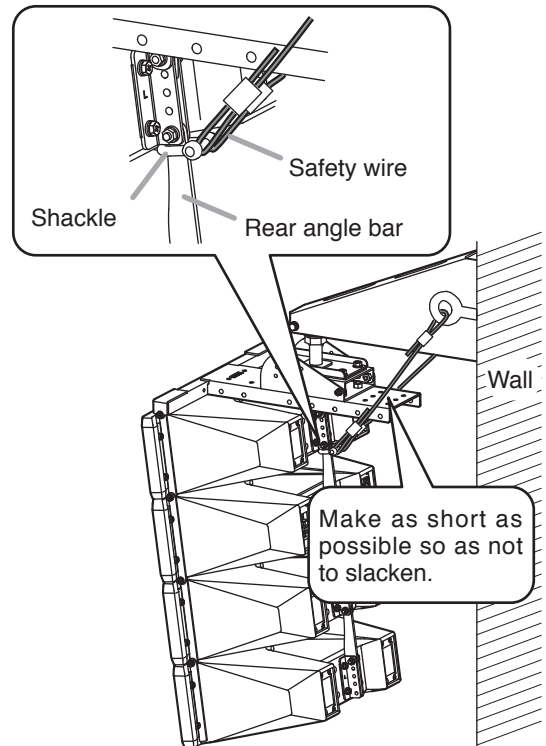

Note

Attach at least 2 safety wires to the shackle, then secure them to the wall as shown above.

11. EQUALIZATION USING A DIGITAL SIGNAL PROCESSOR

The speaker systems are to reproduce wide-band, high-efficiency sound even without the use of an equalizer. However, sound quality can be made even clearer and more dynamic with the addition of a TOA digital signal processor (DSP) set as shown in the table.

• Filter characteristics for using the speaker only

[When using the 0° mode]

| | Filter | Frequency | Gain | Q | Delay |
|--------------------|-------------|-----------|------|-------|-------|
| HX-7B, HX-7W | HPF (12 dB) | 65 Hz | — | 1.000 | 0 ms |
| | PEQ | 160 Hz | 3.0 | 1.011 | |
| | PEQ | 1.75 kHz | -3.5 | 3.633 | |
| | PEQ | 4.62 kHz | -7.0 | 2.145 | |
| | PEQ | 9.25 kHz | -7.5 | 1.414 | |
| HX-7B-WP, HX-7W-WP | HPF (12 dB) | 65 Hz | — | 1.000 | 0 ms |
| | PEQ | 100 Hz | 4.0 | 0.700 | |
| | PEQ | 1.75 kHz | -3.5 | 3.633 | |
| | PEQ | 4.62 kHz | -7.0 | 2.145 | |
| | PEQ | 9.25 kHz | -7.5 | 1.414 | |

[When using the 15° mode]

| | Filter | Frequency | Gain | Q | Delay |
|--------------------|-------------|-----------|------|-------|-------|
| HX-7B, HX-7W | HPF (12 dB) | 65 Hz | — | 1.000 | 0 ms |
| | PEQ | 160 Hz | 3.0 | 1.011 | |
| | PEQ | 1.75 kHz | -3.0 | 3.633 | |
| | PEQ | 4.62 kHz | -7.5 | 2.145 | |
| HX-7B-WP, HX-7W-WP | HPF (12 dB) | 65 Hz | — | 1.000 | 0 ms |
| | PEQ | 100 Hz | 4.0 | 0.700 | |
| | PEQ | 1.75 kHz | -3.0 | 3.633 | |
| | PEQ | 4.62 kHz | -7.5 | 2.145 | |

[When using the 30° mode]

| | Filter | Frequency | Gain | Q | Delay |
|--------------------|-------------|-----------|------|-------|-------|
| HX-7B, HX-7W | HPF (12 dB) | 65 Hz | — | 1.000 | 0 ms |
| | PEQ | 160 Hz | 3.0 | 1.011 | |
| | PEQ | 1.75 kHz | -2.0 | 3.633 | |
| | PEQ | 5.00 kHz | -3.5 | 1.414 | |
| HX-7B-WP, HX-7W-WP | HPF (12 dB) | 65 Hz | — | 1.000 | 0 ms |
| | PEQ | 100 Hz | 4.0 | 0.700 | |
| | PEQ | 1.75 kHz | -2.0 | 3.633 | |
| | PEQ | 5.00 kHz | -3.5 | 1.414 | |

[When using the 45° mode]

| | Filter | Frequency | Gain | Q | Delay |
|--------------------|-------------|-----------|------|-------|-------|
| HX-7B, HX-7W | HPF (12 dB) | 65 Hz | — | 1.000 | 0 ms |
| | PEQ | 160 Hz | 3.0 | 1.011 | |
| | PEQ | 1.75 kHz | -2.5 | 3.633 | |
| | PEQ | 4.62 kHz | -2.5 | 2.456 | |
| HX-7B-WP, HX-7W-WP | HPF (12 dB) | 65 Hz | — | 1.000 | 0 ms |
| | PEQ | 100 Hz | 4.0 | 0.700 | |
| | PEQ | 1.75 kHz | -2.5 | 3.633 | |
| | PEQ | 4.62 kHz | -2.5 | 2.456 | |

[When using the 60° mode]

| | Filter | Frequency | Gain | Q | Delay |
|--------------------|-------------|-----------|------|-------|-------|
| HX-7B, HX-7W | HPF (12 dB) | 65 Hz | — | 1.000 | 0 ms |
| | PEQ | 160 Hz | 3.0 | 1.011 | |
| | PEQ | 5.30 kHz | -3.0 | 2.456 | |
| HX-7B-WP, HX-7W-WP | HPF (12 dB) | 65 Hz | — | 1.000 | 0 ms |
| | PEQ | 100 Hz | 4.0 | 0.700 | |
| | PEQ | 5.30 kHz | -3.0 | 2.456 | |

• Filter characteristics when used with the FB-150 series Subwoofer System

Note

When using the processor with the HX-7 Series and the FB-150 Series, ensure that the wiring polarity of both units is the same.

[When using the 0° mode]

| | Filter | Frequency | Gain | Q | Delay |
|---------------|-------------|-----------|------|-------|-------|
| HX-7 Series | HPF (12 dB) | 90 Hz | — | 0.700 | 0 ms |
| | PEQ | 160 Hz | 3.0 | 1.011 | |
| | PEQ | 1.75 kHz | -3.5 | 3.633 | |
| | PEQ | 4.62 kHz | -7.0 | 2.145 | |
| | PEQ | 9.25 kHz | -7.5 | 1.414 | |
| FB-150 Series | HPF (12 dB) | 30 Hz | — | 1.000 | 0 ms |
| | PEQ | 40 Hz | 3.0 | 1.414 | |
| | LPF (12 dB) | 100 Hz | — | 1.000 | |

[When using the 15° mode]

| | Filter | Frequency | Gain | Q | Delay |
|---------------|-------------|-----------|------|-------|-------|
| HX-7 Series | HPF (12 dB) | 90 Hz | — | 0.700 | 0 ms |
| | PEQ | 160 Hz | 3.0 | 1.011 | |
| | PEQ | 1.75 kHz | -3.0 | 3.633 | |
| | PEQ | 4.62 kHz | -7.5 | 2.145 | |
| FB-150 Series | HPF (12 dB) | 30 Hz | — | 1.000 | 0 ms |
| | PEQ | 40 Hz | 3.0 | 1.414 | |
| | LPF (12 dB) | 100 Hz | — | 1.000 | |

[When using the 30° mode]

| | Filter | Frequency | Gain | Q | Delay |
|---------------|-------------|-----------|------|-------|-------|
| HX-7 Series | HPF (12 dB) | 90 Hz | — | 0.700 | 0 ms |
| | PEQ | 160 Hz | 3.0 | 1.011 | |
| | PEQ | 1.75 kHz | -2.0 | 3.633 | |
| | PEQ | 5.00 kHz | -3.5 | 1.414 | |
| FB-150 Series | HPF (12 dB) | 30 Hz | — | 1.000 | 0 ms |
| | PEQ | 40 Hz | 3.0 | 1.414 | |
| | LPF (12 dB) | 100 Hz | — | 1.000 | |

[When using the 45° mode]

| | Filter | Frequency | Gain | Q | Delay |
|---------------|-------------|-----------|------|-------|-------|
| HX-7 Series | HPF (12 dB) | 90 Hz | — | 0.700 | 0 ms |
| | PEQ | 160 Hz | 3.0 | 1.011 | |
| | PEQ | 1.75 kHz | -2.5 | 3.633 | |
| | PEQ | 4.62 kHz | -2.5 | 2.456 | |
| FB-150 Series | HPF (12 dB) | 30 Hz | — | 1.000 | 0 ms |
| | PEQ | 40 Hz | 3.0 | 1.414 | |
| | LPF (12 dB) | 100 Hz | — | 1.000 | |

[When using the 60° mode]

| | Filter | Frequency | Gain | Q | Delay |
|---------------|-------------|-----------|------|-------|-------|
| HX-7 Series | HPF (12 dB) | 90 Hz | — | 0.700 | 0 ms |
| | PEQ | 160 Hz | 3.0 | 1.011 | |
| | PEQ | 5.30 kHz | -3.0 | 2.456 | |
| FB-150 Series | HPF (12 dB) | 30 Hz | — | 1.000 | 0 ms |
| | PEQ | 40 Hz | 3.0 | 1.414 | |
| | LPF (12 dB) | 100 Hz | — | 1.000 | |

12. COMBINATION WITH THE MATCHING TRANSFORMER

Using the optional MT-200 Matching Transformer allows the speaker system to be connected to a high-impedance amplifier output. This matching transformer is best for use when the distance between the amplifier and speaker is very long, or when multiple speaker systems are parallel-connected to a single amplifier. The MT-200 Matching Transformer can be mounted on the HX-7 Series Speaker System using the HY-MT7 Matching Transformer Adapter.

Regarding the procedure for mounting the transformer on the speaker, refer to the instruction manual supplied with the MT-200 and the installation manual supplied with the HY-MT7.

13. SPECIFICATIONS

| Model No. | | HX-7B | HX-7W |
|-------------------------|--------------------|---|---|
| Enclosure | | Bass-reflex type | |
| Power Handling Capacity | | Continuous pink noise: 250 W (IEC60268-5: 350 W) Continuous program: 750 W | |
| Rated Impedance | | 8 Ω | |
| Sensitivity | | 100 dB (1 W, 1 m) | |
| Frequency Response | | 75 Hz – 20 kHz | |
| Crossover Frequency | | 1.7 kHz | |
| Directivity Angle | | Horizontal: 100° Vertical : Depending on directivity angle mode | |
| Speaker Component | | Low frequency : 13 cm (5.5") cone-type x 8 High frequency: Wave front control horn with compression driver x 4 | |
| Input Terminal | | Speakon NL4MP x 2 and M4 screw terminal, distance between barriers: 9 mm (0.35") | |
| Finish | Enclosure | Polypropylene, black | Polypropylene, white |
| | Punched net | Surface-treated steel plate, black, paint | Surface-treated steel plate, white, paint |
| | Suspension bracket | Steel plate, t 3.0, black, paint | Steel plate, t 3.0, white, paint |
| Dimensions | | 497 (w) x 664 (h) x 274 (d) mm (19.57" x 26.14" x 10.79") | |
| Weight | | 30 kg (66.14 lb) | |

Note: The design and specifications are subject to change without notice for improvement.

• Accessories

Suspension bracket (L, R)*1 1 each
Hex head bolt M6 x 20 with spring and plain washers 4

*1 Suspension bracket L and R are symmetrical to each other.

• Optional products

[HX-7B]

Matching transformer: MT-200*2
Matching transformer adapter: HY-MT7
Speaker mounting bracket: HY-60DB, HY-CN7B, HY-PF7B, HY-VM7B, HY-WM7B*3, HY-C0801*3
Speaker stand adapter: HY-ST7

[HX-7W]

Matching transformer: MT-200*2
Matching transformer adapter: HY-MT7
Speaker mounting bracket: HY-60DW, HY-CN7W, HY-PF7W, HY-VM7W, HY-WM7W*4, HY-C0801W*4
Speaker stand adapter: HY-ST7

*2 HY-MT7 Matching Transformer Adapter is separately required.

*3 HY-VM7B Speaker Rigging Bracket is separately required.

*4 HY-VM7W Speaker Rigging Bracket is separately required.

| Model No. | | HX-7B-WP | HX-7W-WP |
|-------------------------|-------------|---|---|
| Enclosure | | Sealed type | |
| Power Handling Capacity | | Continuous pink noise: 250 W (IEC60268-5: 350 W) Continuous program: 750 W | |
| Rated Impedance | | 8 Ω | |
| Sensitivity | | 100 dB (1 W, 1 m) | |
| Frequency Response | | 105 Hz – 20 kHz | |
| Crossover Frequency | | 1.7 kHz | |
| Directivity Angle | | Horizontal: 100° Vertical : Depending on directivity angle mode | |
| Speaker Component | | Low frequency : 13 cm (5.5") cone-type x 8 High frequency: Wave front control horn with compression driver x 4 | |
| Input Terminal | | M4 screw terminal (supplied with the terminal cover), distance between barriers: 9 mm (0.35") | |
| Water Protection | | IPX4 (Install with every speaker module tilted downward from the horizontal.) | |
| Finish | Enclosure | Polypropylene, black | Polypropylene, white |
| | Punched net | Surface-treated steel plate, black, rust proof coating | Surface-treated steel plate, white, rust proof coating |
| Dimensions | | 497 (w) x 664 (h) x 274 (d) mm (19.57" x 26.14" x 10.79") | |
| Weight | | 30 kg (66.14 lb) | |

Note: The design and specifications are subject to change without notice for improvement.

• **Accessories**

| | |
|----------------------------|---|
| Terminal cover | 1 |
| Tapping screw 4 x 12 | 4 |
| Rubber gasket | 1 |

• **Optional products**

[HX-7B]

| | |
|-------------------------------|--|
| Matching transformer: | MT-200* |
| Matching transformer adapter: | HY-MT7 |
| Speaker mounting bracket: | HY-60DB-WP, HY-CN7B-WP, HY-TM7B-WP, HY-MS7B-WP |

[HX-7W]

| | |
|-------------------------------|--|
| Matching transformer: | MT-200* |
| Matching transformer adapter: | HY-MT7 |
| Speaker mounting bracket: | HY-60DW-WP, HY-CN7W-WP, HY-TM7W-WP, HY-MS7W-WP |

* HY-MT7 Matching Transformer Adapter is separately required.

Traceability Information for Europe

Manufacturer:
TOA Corporation
7-2-1, Minatojima-Nakamachi, Chuo-ku, Kobe, Hyogo,
Japan

Authorized representative:
TOA Electronics Europe GmbH
Suederstrasse 282, 20537 Hamburg,
Germany