

# A-2030/2060/2120/2240 Mixer Power Amplifiers

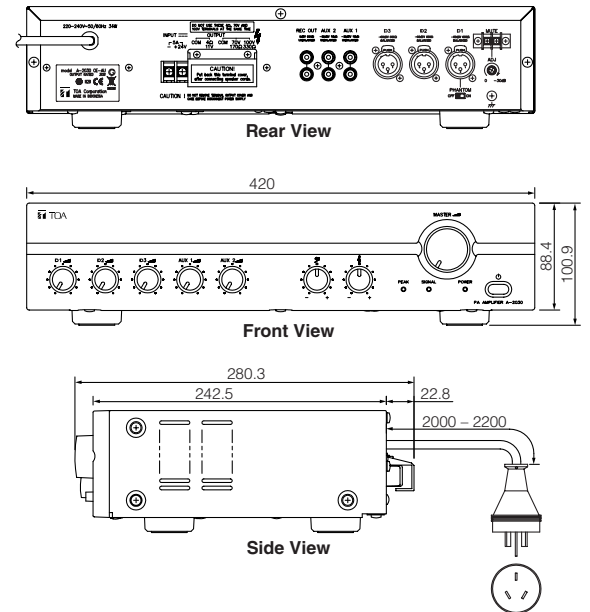

## APPEARANCE AND DIMENSIONAL DIAGRAM (A-2000 Series)

### A-2030/2060



## DESCRIPTION

A-2000 Series Mixer Power Amplifiers are designed to be highly cost-effective solutions to the demands of PA applications. They offer high levels of performance and versatility and are especially well-suited for broadcasting paging and supplying background music in schools, offices, shops, factories, mosques, churches, and large meeting rooms. The A-2000 series makes available a wide range of power outputs (A-2030: 30W, A-2060: 60W, A-2120: 120W, A-2240: 240W), with a frequency response of 50 – 20,000 Hz and distortion under 1%. Three balanced/XLR3-31 type MIC inputs and two unbalanced/RCA pin jack AUX inputs, along with high and low impedance balanced (floating) speaker outputs and unbalanced REC outputs ensure operational versatility.

Phantom power and muting are available on MIC 1, along with tone control for bass and treble. Power, signal and peak indicators are provided. In addition, the P-2240 Booster Amplifier offers a means of increasing power amplification for system expansion through adding more speakers.

## FEATURES

### High cost-performance

- Suitable for commercial audio systems in schools, offices, shops, factories, houses of worship, and large meeting rooms
- Equipped with balanced mic. inputs for better isolation from external noise, compared to unbalanced inputs
- Improved durability compared with conventional TOA models

### Flexibility

- A wide range of power outputs from 30W to 240W
- Offers a comfortable acoustic space thanks to tone control at bass and treble
- Both AC and DC operation possible
- Phantom power provided to MIC1, for supplying power to a condenser microphone

### Easy to handle

- Scratch- and fingerprint-resistant front panel
- Easy and quick volume control with master volume knob

### A-2120/2240

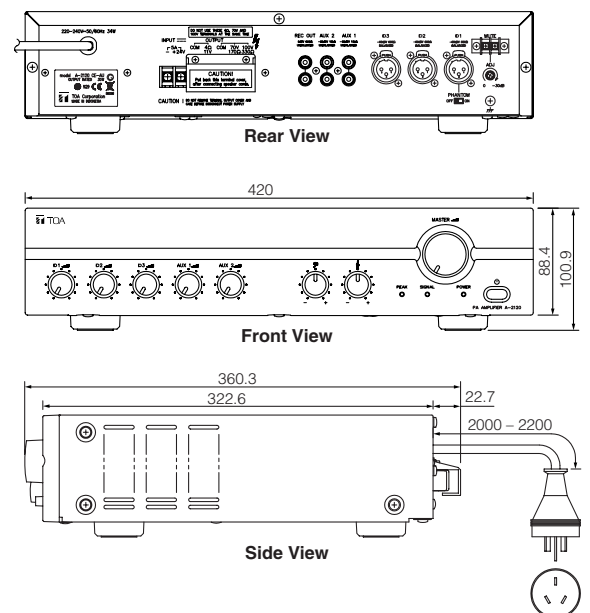

CE-AU Version

# Frequency Response

**A-2030**

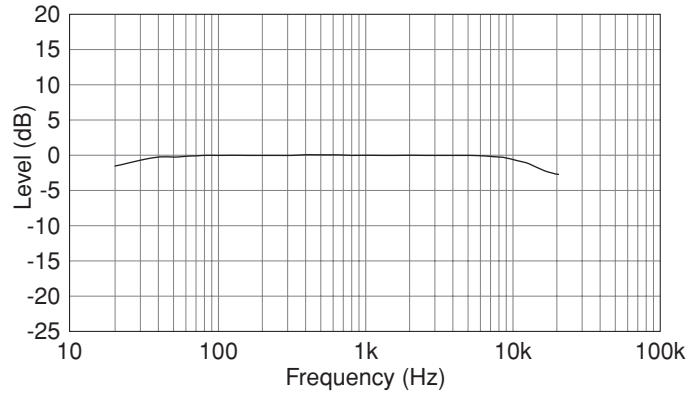

**A-2060**

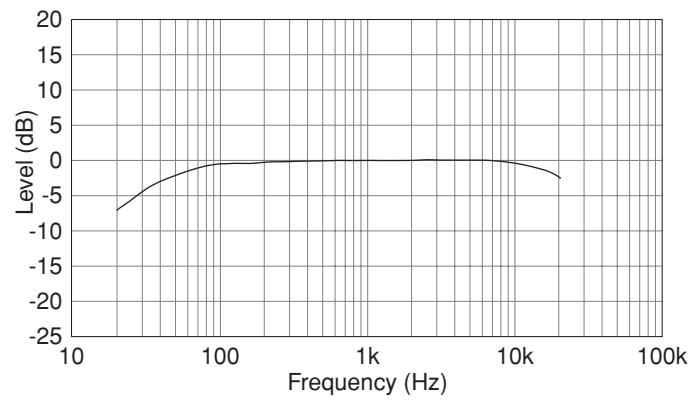

**A-2120**

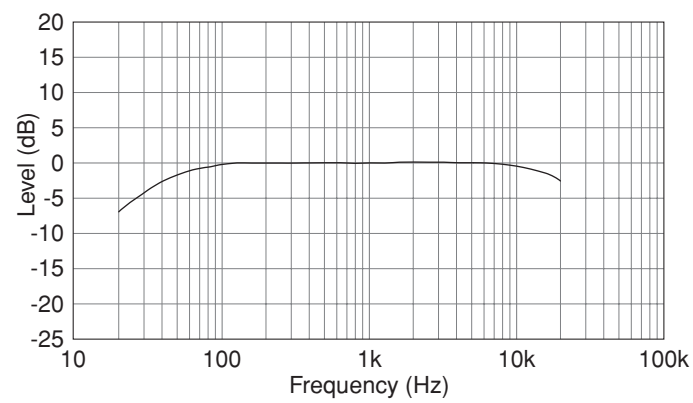

**A-2240**

**P-2240**

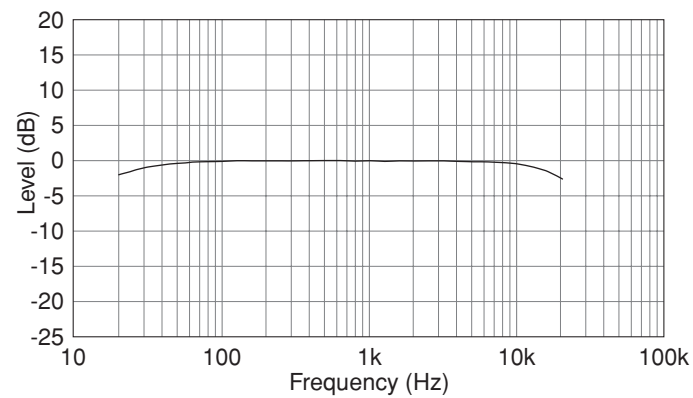

## CONNECTION EXAMPLE

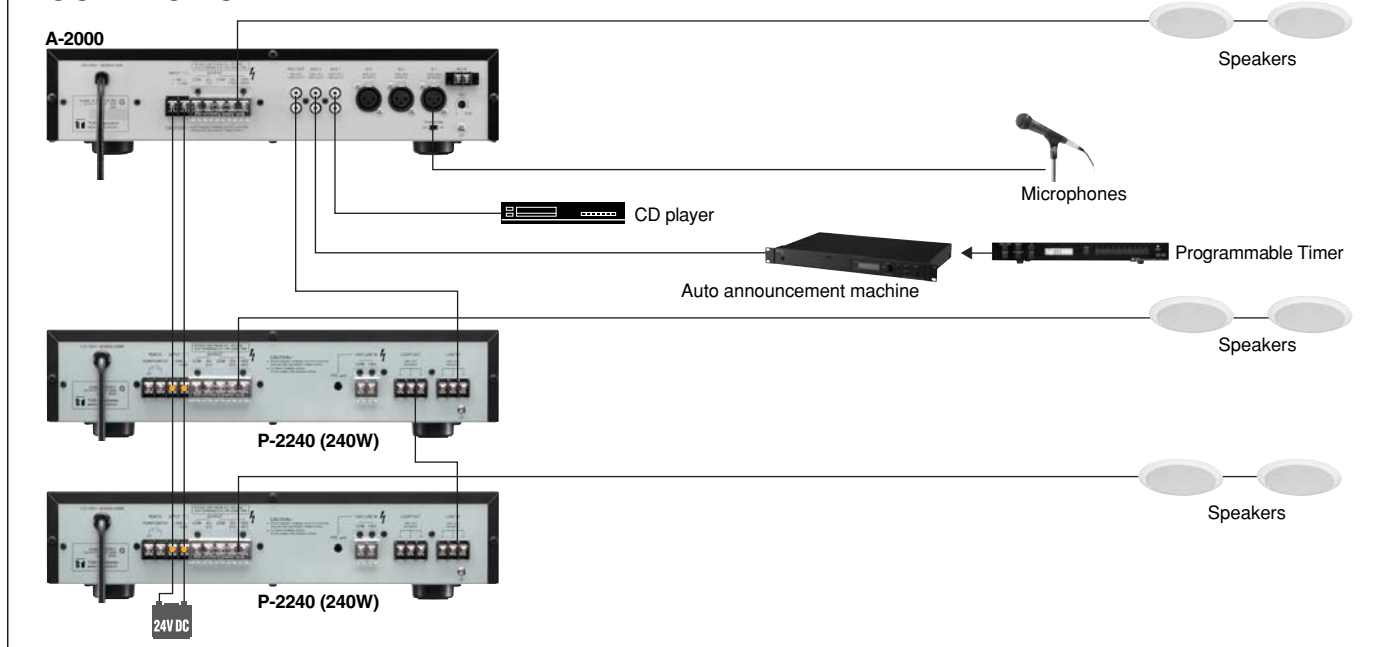

## APPEARANCE AND DIMENSIONAL DIAGRAM (P-2240)

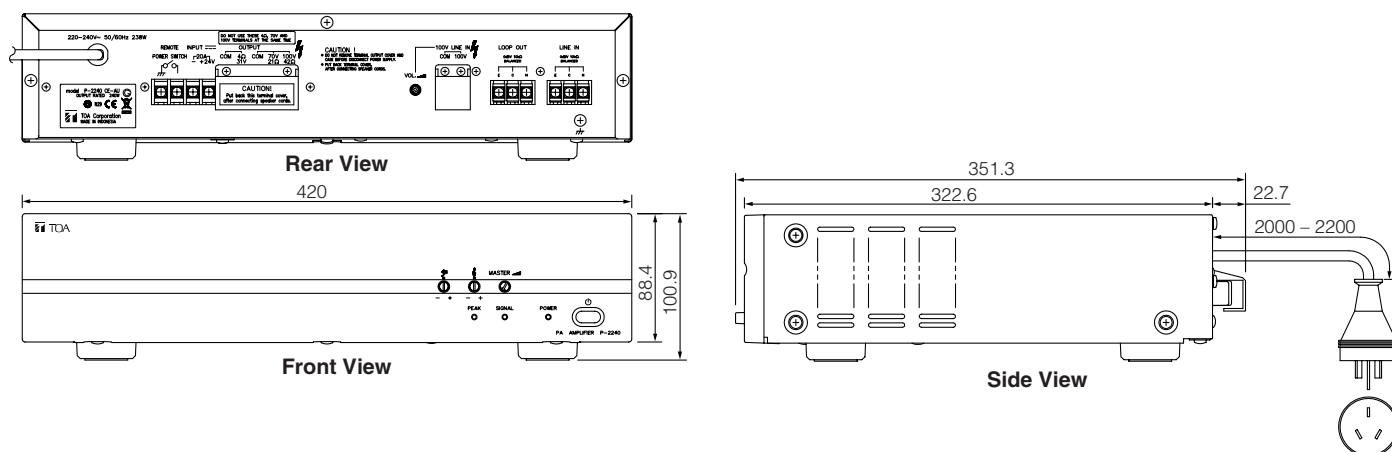

## SPECIFICATIONS

Model No.	A-2030	A-2060	A-2120	A-2240	P-2240
Power Source	220 – 240V AC or 24V DC				
Rated Output	30W	60W	120W	240W	240W
Power Consumption	34W (EN60065), 78W (AC operation at rated output), 2A (DC operation at rated output)	72W (EN60065), 150W (AC operation at rated output), 4A (DC operation at rated output)	124W (EN60065), 260W (AC operation at rated output), 8A (DC operation at rated output)	238W (EN60065), 520W (AC operation at rated output), 15A (DC operation at rated output)	238W (EN60065), 520W (AC operation at rated output), 15A (DC operation at rated output)
Frequency Response	50 – 20,000Hz (±3dB)				
Distortion	Under 1% at 1kHz, 1/3 rated power				
Input	MIC 1 – 3: -60dB*, 600Ω, electronically balanced, XLR3-31 type AUX 1, 2: -20dB*, 10kΩ, unbalanced, RCA pin jack Mute: Contact screw terminal (for MIC 1)				Line in: 0dB*, 10kΩ, balanced, screw terminal 100V line in: 40dB*, 330kΩ, unbalanced, screw terminal Power remote control: Make contact
Output	Loop out Speaker out High impedance Low impedance Rec. out	— Balanced (floating) 170Ω (100V), 83Ω (70V) 4Ω (11V) 0dB*, 600Ω, unbalanced, RCA pin jack	— Balanced (floating) 170Ω (100V), 83Ω (70V) 4Ω (15.5V) 0dB*, 600Ω, unbalanced, RCA pin jack	— Balanced (floating) 83Ω (100V), 42Ω (70V) 4Ω (22V) 0dB*, 600Ω, unbalanced, RCA pin jack	— Balanced (floating) 42Ω (100V), 21Ω (70V) 4Ω (31V) 0dB*, 600Ω, unbalanced, RCA pin jack
Phantom Power	DC +21V (MIC 1)				
S/N Ratio	Over 60dB				
Ventilation	—			Fan cooling	
Tone Control	Bass: ±10dB at 100Hz/Treble: ±10dB at 10kHz				
Muting	MIC 1: Mutes other input signals by 0 – 30dB attenuation				
Indicator	Power, signal, peak				
Finish	Panel: ABS resin, black/Case: Steel plate, black				
Dimensions	420 (W) × 100.9 (H) × 280.3 (D)mm		420 (W) × 100.9 (H) × 360.3 (D)mm		420 (W) × 100.9 (H) × 351.3 (D)mm
Weight	5kg	7kg	10.8kg	13.2kg	13.2kg

# ARCHITECT'S AND ENGINEER'S SPECIFICATIONS

## **A-2030 Mixer Power Amplifier (30-Watt)**

The mixer power amplifier shall operate on AC mains or 24 V DC power, and shall control and mix 3 balanced (XLR3-31 type) MIC and 2 unbalanced (RCA pin jack) AUX inputs. Speaker outputs shall be balanced (floating) high-impedance and low-impedance, and there shall be a low-impedance REC out. The amplifier shall meet the following performance criteria: Power output shall be 30 W at less than 1% THD (at 1 kHz, 1/3 rated power). Frequency response shall be 50 Hz to 20 kHz ( $\pm 3$  dB), with an S/N ratio of over 60 dB. Phantom power (DC +21 V) and muting (of other input signals by 0 – 30 dB attenuation) shall be available for MIC 1. Bass Tone Control shall be  $\pm 10$  dB at 100 Hz, and Treble Tone Control shall be  $\pm 10$  dB at 10 kHz. Power, signal and peak indicators shall be provided. The panel shall be ABS black resin, and the case black steel plate. Dimensions shall be 420 (W)  $\times$  100.9 (H)  $\times$  280.3 (D) mm and weight is 5 kg. The mixer power amplifier shall be TOA model A-2030.

## **A-2120 Mixer Power Amplifier (120-Watt)**

The mixer power amplifier shall operate on AC mains or 24 V DC power, and shall control and mix 3 balanced (XLR3-31 type) MIC and 2 unbalanced (RCA pin jack) AUX inputs. Speaker outputs shall be balanced (floating) high-impedance and low-impedance, and there shall be a low-impedance REC out. The amplifier shall meet the following performance criteria: Power output shall be 120 W at less than 1% THD (at 1 kHz, 1/3 rated power). Frequency response shall be 50 Hz to 20 kHz ( $\pm 3$  dB), with an S/N ratio of over 60 dB. Phantom power (DC +21 V) and muting (of other input signals by 0 – 30 dB attenuation) shall be available for MIC 1. Bass Tone Control shall be  $\pm 10$  dB at 100 Hz, and Treble Tone Control shall be  $\pm 10$  dB at 10 kHz. Power, signal and peak indicators shall be provided. The panel shall be ABS black resin, and the case black steel plate. Dimensions shall be 420 (W)  $\times$  100.9 (H)  $\times$  360.3 (D) mm, and weight 10.8 kg. The mixer power amplifier shall be TOA model A-2120.

## **P-2240 (CE-AU version) Booster Amplifier (240-Watt)**

The booster amplifier shall operate on AC mains or 24 V DC power, and shall control and mix 1 balanced (screw terminal) Line in and 1 unbalanced (screw terminal) 100 V Line inputs. Outputs shall be balanced Loop out and balanced high and low impedance (floating) Speaker out. The amplifier shall meet the following performance criteria: Power output shall be 240 W at less than 1% THD (at 1 kHz, 1/3 rated power). Frequency response shall be 50 Hz to 20 kHz ( $\pm 3$  dB), with an S/N ratio of over 60 dB. Bass Tone Control shall be  $\pm 10$  dB at 100 Hz, and Treble Tone Control shall be  $\pm 10$  dB at 10 kHz. Power, signal and peak indicators, and fan cooling ventilation shall be provided. The panel shall be ABS black resin, and the case black steel plate. Dimensions shall be 420 (W)  $\times$  100.9 (H)  $\times$  351.3 (D) mm, and weight 13.2kg. The booster amplifier shall be TOA model P-2240.

## **A-2060 Mixer Power Amplifier (60-Watt)**

The mixer power amplifier shall operate on AC mains or 24 V DC power, and shall control and mix 3 balanced (XLR3-31 type) MIC and 2 unbalanced (RCA pin jack) AUX inputs. Speaker outputs shall be balanced (floating) high-impedance and low-impedance, and there shall be a low-impedance REC out. The amplifier shall meet the following performance criteria: Power output shall be 60 W at less than 1% THD (at 1 kHz, 1/3 rated power). Frequency response shall be 50 Hz to 20 kHz ( $\pm 3$  dB), with an S/N ratio of over 60 dB. Phantom power (DC +21 V) and muting (of other input signals by 0-30 dB attenuation) shall be available for MIC 1. Bass Tone Control shall be  $\pm 10$  dB at 100 Hz, and Treble Tone Control shall be  $\pm 10$  dB at 10 kHz. Power, signal and peak indicators shall be provided. The panel shall be ABS black resin, and the case black steel plate. Dimensions shall be 420 (W)  $\times$  100.9 (H)  $\times$  280.3 (D) mm, and weight 7 kg. The mixer power amplifier shall be TOA model A-2060.

## **A-2240 Mixer Power Amplifier (240-Watt)**

The mixer power amplifier shall operate on AC mains or 24 V DC power, and shall control and mix 3 balanced (XLR3-31 type) MIC and 2 unbalanced (RCA pin jack) AUX inputs. Speaker outputs shall be balanced (floating) high-impedance and low-impedance, and there shall be a low-impedance REC out. The amplifier shall meet the following performance criteria: Power output shall be 240 W at less than 1% THD (at 1 kHz, 1/3 rated power). Frequency response shall be 50 Hz to 20 kHz ( $\pm 3$  dB), with an S/N ratio of over 60 dB. Phantom power (DC +21 V) and muting (of other input signals by 0 – 30 dB attenuation) shall be available for MIC 1. Bass Tone Control shall be  $\pm 10$  dB at 100 Hz, and Treble Tone Control shall be  $\pm 10$  dB at 10 kHz. Power, signal and peak indicators, and fan cooling ventilation shall be provided. The panel shall be ABS black resin, and the case black steel plate. Dimensions shall be 420 (W)  $\times$  100.9 (H)  $\times$  360.3 (D) mm, and weight 13.2kg. The mixer power amplifier shall be TOA model A-2240.