



DNH

HPA-60

Morrison's Public Address
Phone: 0407442822
Email: sales@morrison sav.com.au

ISO 9001 CERTIFIED

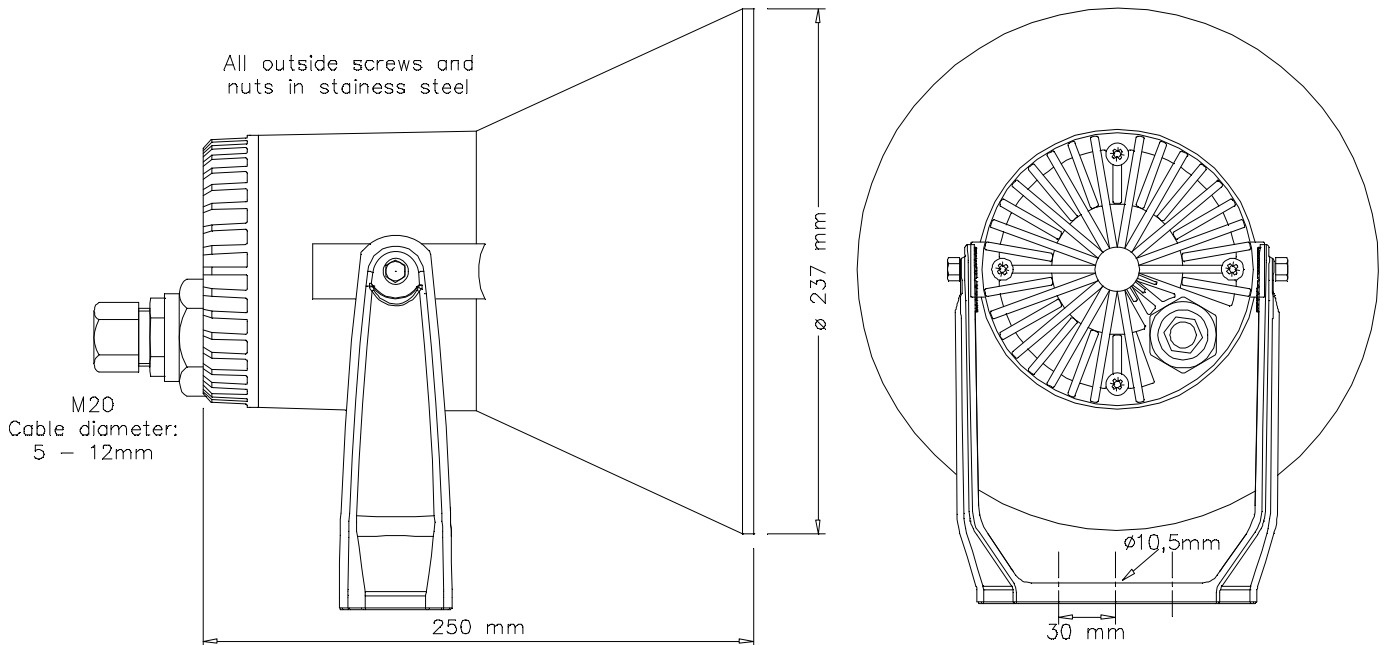

Sound pressure levels at 1W/1m

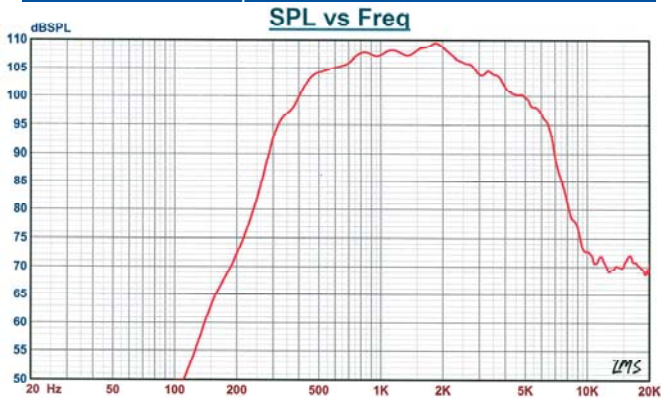

Specifications

Material / Color	PA/aluminum alloy / RAL 7035
Mounting	Bracket
Termination	Inside screw terminal
Weight w/transformer	1,9 kg
IP-rating	67
Max. / min. amb. temp	150 °C / -50 °C
Rated / max. power	60 W / 60 W
SPL 1W/1m	110 dB
SPL rated power	126 dB
Effective freq. range	310 – 8000 Hz
Dispersion (-6dB) 1kHz / 4kHz	115° / 30°
Directivity factor, Q	
Options	Impedances, colors, labels

Installation, Operation and Maintenance Procedures

- Remove hexagonal nut, lead cable through cable gland and connect cable to terminals.
- Screw hexagonal nut back on and tighten cable gland.
- To change the position of the loudspeaker please adjust the bracket (by loosening / tightening the screws) as required.
- Stainless steel bracket is available as an option.
- For optimum performance, always use the correct voltage / power and operate within the frequency limits as stated.
- Do not open loudspeaker when energized.
- This loudspeaker is supplied with a 2 year warranty against defective workmanship.

NB! Not available with transformer. Separate matching transformer can be delivered.

DNH reserves the right to alter specifications without notice

